

# Running Procedure

---

VAF®

Rev.: 1

# VAF<sup>®</sup>

---

RS-RP-VAF-1 Rev.1: Updated requirements for acceptance criteria and break outs

# Table of Content

---

- Table of Content
  - VAF®
  - Technical data sheet
  - Running and handling
  - Visual inspection and field repair
  - Transportation, handling and storage

This document contains the recommended practices for the installation of voestalpine tubulars proprietary connections. This is not comprehensive and is meant only as general guidance, based on best industry practices.

The user assumes all responsibility for the safe and effective implementation of these practices. Further, it is the user's responsibility to provide competent and knowledgeable personnel, as well as appropriate and well maintained equipment. Equipment manuals must be followed. In case of conflict safety has priority.

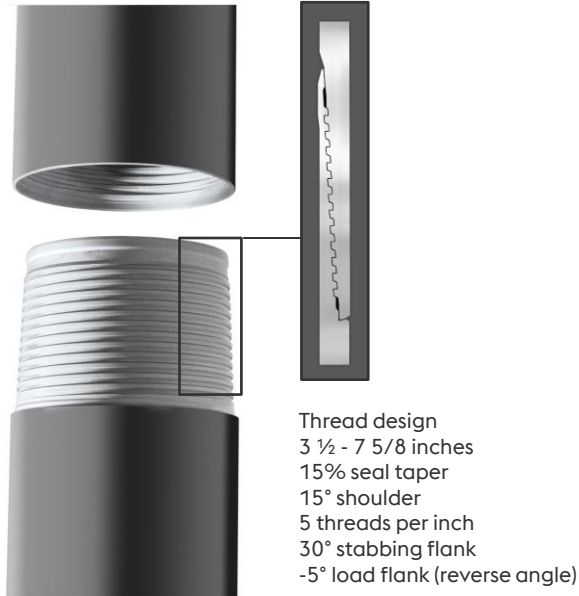

- VAF® is a real flush premium connection and therefore the perfect solution for slim hole applications.
- **Metal to metal seal**– The optimal contact pressure in the seal area ensures 100% gas tightness.
- **Thread design** – manufactured in conformity with the API 5CT standard, the voestalpine Tubulars proprietary standard and customer special requirements
- **Positive Make-up stop** – external shoulder provides a positive make-up torque stop and allows visual confirmation of proper make-up
- **Smooth Internal Profile**– minimizes turbulences and also provides good conditions for internal coating

# Dimensions and torque values

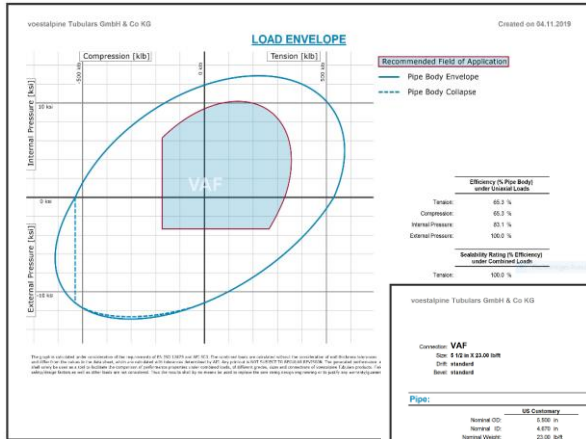

Dimensions and torque values will be provided through our datasheet generator:  
<http://www.voestalpine.com/tubulars/en> ->  
 Customer service -> Datasheet generator

voestalpine Tubulars GmbH & Co KG Created on 04.11.2019

**TECHNICAL DATA SHEET**

Connection: **VAF** Grade: **L80-1**

Size: **5 1/2 in x 23.00 mm**

	US Customary	Metric	US Customary	Metric
Yield Strength Min:	60,000 psi	4137 MPa	Yield Strength Min:	605 MPa
Yield Strength Max:	90,000 psi	6205 MPa	Yield Strength Max:	605 MPa
Tensile Strength Min:	90,000 psi	6205 MPa	Tensile Strength Min:	605 MPa

**Pipe:**

	US Customary	Metric	US Customary	Metric
Nominal OD:	5.500 in	139.75 mm	Wall Thickness:	0.415 in
Actual OD:	4.830 in	122.62 mm	Standard Dev:	0.008 in
Nominal Weight:	23.00 lb/ft	33.57 kg/m	Pipe Body Yield Strength:	530 MPa
Pipe Class Section:	6 650 07	4,277 A1 06P		

**Connection:**

	US Customary	Metric	US Customary	Metric
OD:	5.600 in	142.25 mm	Threads per inch:	8 Threads
ID:	4.614 in	117.20 mm		
Length:	- in	- mm		

**Connection Performance (Uniaxial Load):**

	US Customary	Metric	US Customary	Metric
Joint Strength:	248 kN	1.50 tN	Tension Efficiency:	65.3 %
Collapse Resistance:	11,100 psi	77.00 MPa	Displacement:	1,206 µm/ft
Internal Fluid Pressure:	8,784 psi	60.60 MPa	Production:	0.880 gal/ft
Load on Coupling Face:	1 kN	0.225 lbf		

**Field Make Up (Friction Factor = 1.0):**

	US Customary	Metric	US Customary	Metric
Minimum Torque:	0.200 ft-lb	0.270 Nm	Make-Up Loss:	4.821 ft-lb
Optimum Torque:	4.375 ft-lb	5.900 Nm	Yield Torque:	4,700 ft-lb
Maximum Torque:	4,700 ft-lb	6,370 Nm		
Min. Torque on Elevator:	20 %			

voestalpine  
Since 1877

- Torques are valid for dope with friction factor 1 at room temperature
- Max. torque: optimum +10%
- Min. torque: optimum -10%
- Slip type elevator has to be used

# Running and handling

---

## ■ Equipment

### ■ Elevator

- slip type – clean and sharp dies

### ■ Derrick

- Blocks are centered over rotary table

### ■ Power tong

- Correct size and calibrated
- Torque-turn monitoring system

## ■ Pipe handling

- Thread protectors in place
- No hooks to lift pipes
- No rough handling
- Use proper racks

## ■ Preparation

### ■ Cleaning

- Remove and clean protectors
- Clean pin and box
- Prevent corrosion

- Diesel and oil-based products are not recommended as cleaning solvent
- Prevent corrosion

## ■ Drifting

- Drift pipe on rack – start from box end

## ■ Visual inspection

- Check each pipe (see page 12)
- Apply clean and dry protectors

## ■ Pipe tally

## ■ Running

### ■ Lifting

- Remove pin protectors just before lifting/stabbing
- Use proper handling and lifting plugs
- Only plugs originate from voestalpine Tubulars licensed machine shops shall be used
- Plugs shall be marked with : VAF - LP - size - mark of manufacturer – maximum load
- Plugs shall show indicators for minimum and maximum make up

# Running and handling

- Thread of plug shall be shot peened and phosphated
- Remove all storage compound before usage
- Check visually the condition of the plug and keep it clean
- Apply molykote spray from time to time
- Make up the plugs by hand and snug up with the aid of a steel bar

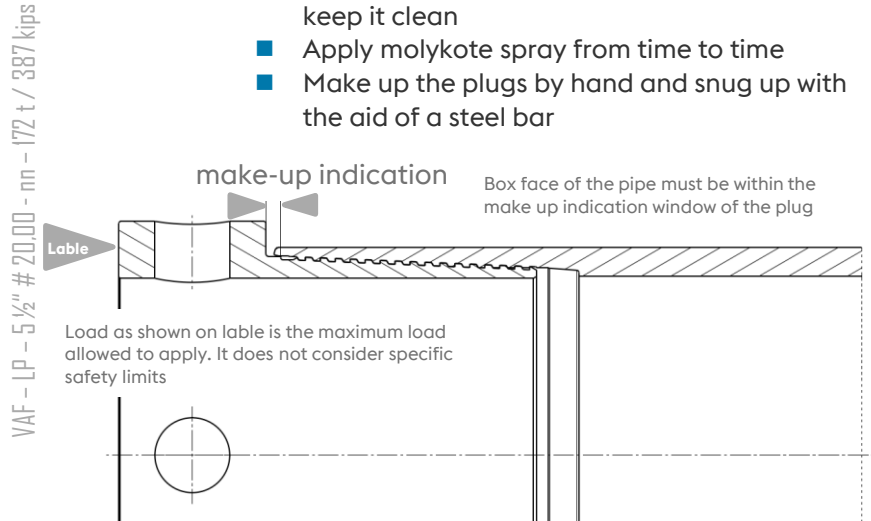

## ■ Stabbing

- Clean the connection with compressed air
- Check seal area for damages
- Apply thread compound – pin & box

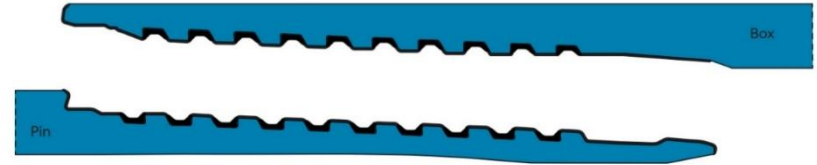

API-modified running compound with known friction factor between 0,8 and 1,2 is recommended. Dope shall be applied uniform on pin and box as a thin layer (thread profile shall be visible after final application of dope).

- Use a stabbing guide
- Lower carefully
- Maintain good alignment

# Running and handling

## ■ Make-up

- Start slowly in high gear with open back-up
- If connection jams (torque increases immediately)
  - Stop and release tong
  - Disengage connection / place back-up on pipe body at a reasonable distance from connection
  - Clean connection / visual inspection
  - If questionable - set aside
  - If o.k. – stab again
- If connection stabs correct
  - Increase speed to spin-in (max. 25 rpm)
  - Assemble until torque increase
  - Stop rotation / close back-up
- Finish in low gear and with speed less than 10 rpm
  - Approximately 1 to 2 turns before shouldering

## ■ Acceptance

- Final torque between maximum and minimum
  - Use correct friction factor of dope
  - Friction factor might be affected by extreme temperatures
- Delta torque shall be at least 20 % of minimum recommended torque as per Datasheet
  - See diagram on page 9
  - Proceed as described under Break-out if 30% delta torque couldn't be achieved
- No plastic deformation
- Increase of torque shall be reasonable uniform and smooth
- Connection must shoulder

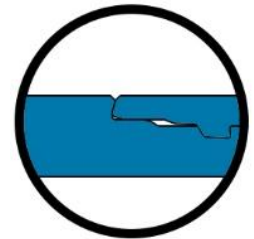

# Running and handling

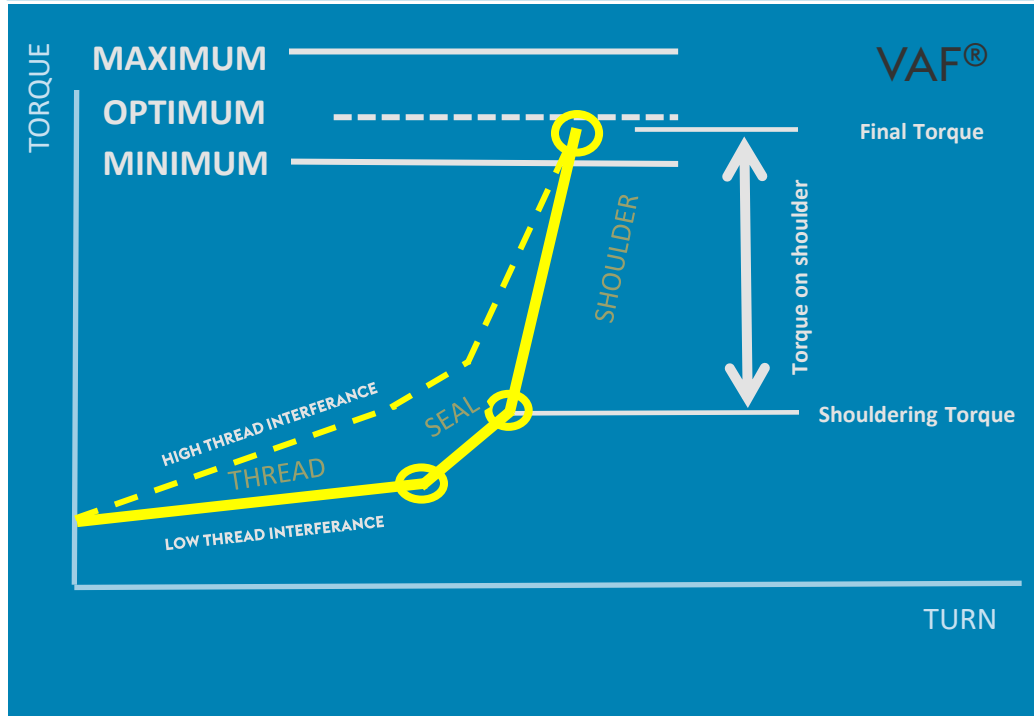

Torque on shoulder  
= Final Torque – Shouldering Torque  
= Delta Torque

Minimum 20 % torque on shoulder  
(Delta Torque).

# Running and handling

---

- Break-out
  - Place back up tong on coupling mill side
  - Set up power tongs to low gear
  - Speed shall be less than 10 rpm
  - Slowly lift the pin out of the box
  - Handle with care / use protectors
  - Clean pin and box
  - Visual inspection / page 13
  - Prepare for the re-run as described under Make-up
    - Only, if no mechanical damages are visible or, if mechanical damages can be repaired, which shall be done before the re-run
    - Apply thread compound – pin & box
  - If make-up graph is still not acceptable
    - Proceed as described under Break-out
    - Maximal 2 re-runs allowed
    - After 2<sup>nd</sup> re-run, pipes shall be set aside for further investigation
- Any problems during make-up or break-out should be reported immediately
  - Used equipment, thread compound, torques used, assembly speed, .....
- Any questionable joint, set aside for evaluation, shall be brought to a disposition
  - Accepted or rejected
  - If rejected it must be properly marked

# Running and handling

- Thread lock compound
  - Pin
    - Thread lock compound shall be applied on the first two-thirds of the threads. No other compound on pin.
  - Box
    - No thread lock compound or dope compound on Box

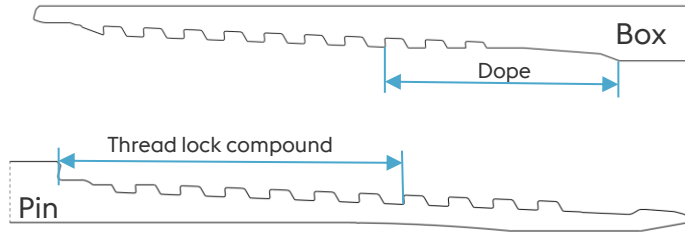

# Visual inspection and field repair

- 1 Torque shoulder
- 2 Seal
- 3 Clearance
- 4 Thread length
- 5 Cylindrical section
- 6 Internal bore/machined
- 7 Taper run out
- 8 Chamfer
- 9 Pin face
- 9-2 Nose radius
- 1-5 Radius

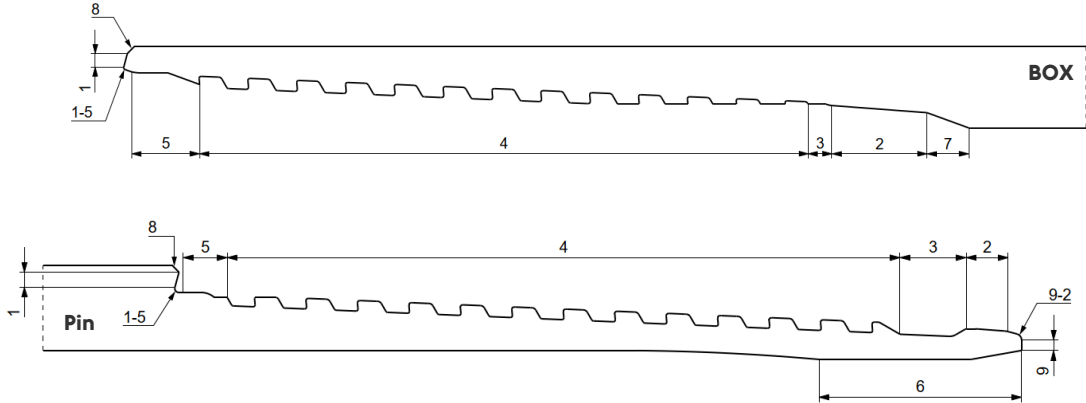

Design 1

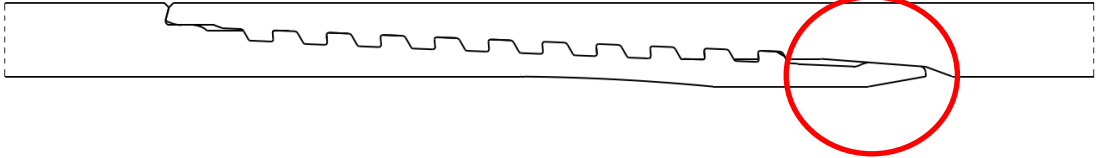

Design 2

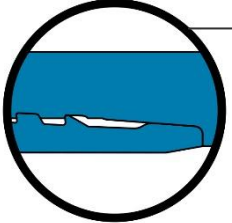

# Visual inspection and field repair

## Pin

Element	Area	Rust	Rust + Pitting	Burrs	Scratches	Dent
Torque shoulder	1	Remove with abrasive fleece	Grind to smooth surface with emery paper	N/A	Grind to smooth surface with emery paper	Grind to smooth surface with file and emery paper
Seal	2	Remove with abrasive fleece	Recut Pin	N/A	Minor remove with abrasive fleece	Recut Pin
Clearance	3	Remove with abrasive fleece	Remove rust with abrasive fleece. Pitting is accepted.	N/A	Accepted	Accepted
Thread length	4	Remove with abrasive fleece	Grind to smooth surface with emery paper	N/A	Accepted	Grind to smooth surface with file and emery paper
Cylindrical section	5	Remove with abrasive fleece	Grind to smooth surface with emery paper	N/A	Accepted	Grind to smooth surface with file and emery paper
Internal bore	6	Remove with abrasive fleece	Remove rust with abrasive fleece. Pitting is accepted.	N/A	Accepted	Accepted
Chamfer	8	Remove with abrasive fleece	Grind to smooth surface with emery paper	N/A	Grind to smooth surface with emery paper	Grind to smooth surface with file and emery paper
Pin face	9	Remove with abrasive fleece	Grind to smooth surface with emery paper	N/A	Grind to smooth surface with emery paper	Grind to smooth surface with file and emery paper
Nose radius	9-2	Remove with abrasive fleece	Grind to smooth surface with emery paper	N/A	Grind to smooth surface with emery paper	Grind to smooth surface with file and emery paper
Radius	1-5	Remove with abrasive fleece	Remove rust with abrasive fleece. Pitting is accepted.	N/A	Grind to smooth surface with emery paper	Grind to smooth surface with file and emery paper

a\* Up to 2 thread-turns may be imperfect if not more than ¼ of a turn is affected. If more than 2 thread-turns / or more than a half turn in total / are affected, hand-repair may be accepted after approval by voestalpine Tubulars specialist.

Abrasive fleece : 400 / 500 (superfine)  
Emery paper : 300 -400 (superfine)

# Visual inspection and field repair

## Box

Element	Area	Rust	Rust + Pitting	Burrs	Scratches	Dent
Torque shoulder	1	Remove with abrasive fleece	Grind to smooth surface with emery paper	N/A	Grind to smooth surface with emery paper	Grind to smooth surface with file and emery paper
Seal	2	Remove with abrasive fleece	Re-cut Box	N/A	Remove with abrasive fleece	Re-cut Box
Clearance	3	Remove with abrasive fleece	Remove rust with abrasive fleece. Pitting is accepted.	N/A	Accepted	Accepted
Thread length	4	Remove with abrasive fleece	Grind to smooth surface with emery paper	Grind to smooth surface with emery paper	Accepted	Grind to smooth surface with file and emery paper
Cylindrical section	5	Remove with abrasive fleece	Remove rust with abrasive fleece. Pitting is accepted.	N/A	Grind to smooth surface with emery paper	Grind to smooth surface with file and emery paper
Run out	7	Remove with abrasive fleece	Remove rust with abrasive fleece. Pitting is accepted.	Accepted	Accepted	Accepted
Chamfer	9	Remove with abrasive fleece	Remove with abrasive fleece	N/A	Grind to smooth surface with emery paper	Grind to smooth surface with file and emery paper
Radius	1-5	Remove with abrasive fleece	Remove with abrasive fleece	N/A	Remove with abrasive fleece	Remove with abrasive fleece

General: On phosphated surfaces, the phosphate layer shall not be removed excessively by hand – repair (except area 7,8 and 10). Minor removal is acceptable as it is.

Heavier removal can be accepted after approval by voestalpine Tubulars specialists. Phosphate and/or corrosion protection spray should be applied (time for drying shall be given).

# Transportation, Handling and Storage

(as recommended by API 5C1)

## ■ Transportation

- Load pipe on bolsters and tie down with suitable chains or straps at the bolsters
- Load pipe with all couplings on the same end of the truck
- Do not overload the truck

## ■ Handling

- Before loading or unloading thread protectors should be in place
- Do not unload pipe by dropping
- Avoid rough handling which might damage the threads or the body of the pipe
- When rolling pipe, on the rack, keep pipe parallel and do not allow pipe to strike the ends
- Do not use hooks to lift pipes



# Transportation, Handling and Storage

(as recommended by API 5C1)

## ■ Storage

- At least every six month some of the pin and box thread protectors should be removed at random and the threads checked for corrosion
- First tier of pipes should be no less than 1,5 feet (approximately 0,5m) from the ground
- Pipes should properly rest on supports to prevent bending and damages
- Between the successive layers of pipes you should provide wooden strips as separators
- Do not stack pipes higher than 9 feet (appr. 3 m)
- Only use thread protectors that correspond to the threaded pin/box ends
- Do not mix different pipes in the stack
- All protectors must be secured and should have no damage

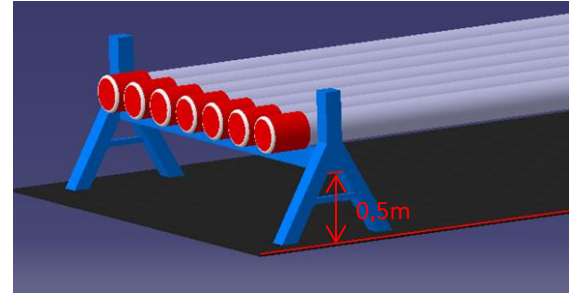

# Thank you

---

**voestalpine Tubulars GmbH & Co KG**  
[www.voestalpine.com/tubulars](http://www.voestalpine.com/tubulars)

**voestalpine**  
ONE STEP AHEAD.