

GUIDELINES FOR HANDLING AND STORAGE

voestalpine clad plates

CONTENT

- 3 Scope of document

- 3 Handling and storage guidelines for clad plates
 - 3 » Handling at mill
 - 3 » Packaging of clad plates
 - 4 » Loading, unloading and storage of clad plates
 - 9 » Non-conformance handling

SCOPE OF DOCUMENT

This guideline defines requirements for handling and storage of clad plates and applies to all shippers and carriers which handle or ship plate material on voestalpine's behalf. Deviate requirements can only be fulfilled within a defined range and only in prior agreement with voestalpine.

This guideline does not supersede relevant codes, best practices, standards, contractual documents, or project specific instructions relating to the work to be performed, except where the requirements herein are more stringent and approved by voestalpine.

HANDLING AND STORAGE GUIDELINES FOR CLAD PLATES

HANDLING AT MILL

Clad plates from voestalpine Grobblech are being manufactured to meet highest standards. Especially the grinded alloy clad material surface is vulnerable to mechanical damage and ferritic contamination. At voestalpine mill, clad plates are handled and processed with best possible care to prevent any damage:

- » Material is always stored in covered areas and on an even hard surface.
- » Clad plates are moved only by cranes equipped with suitable loading magnets or hooks/clamps.
- » Clad plates are arranged with the clad side on top. Material is stacked with hardwood timbers between plates. After grinding, each individual plate is covered with corrugated cardboard to protect the grinded side.

To preserve the perfect condition of finished clad plates, these have to be treated and processed with care and caution also after leaving mill's workshop.

PACKAGING OF CLAD PLATES

The packaging of clad plates is designed considering ecological and economical aspects with the aim to limit required packaging materials to a reasonable extent. Main focus is kept on the protection of the vulnerable grinded alloy clad side. Packaging provides protection against dirtying and minor mechanical impact (e.g. causing skin-deep scratches), but is not suitable to prevent damage from major mechanical impact caused by rough treatment. The packaging is not air- or water tight and thereby not intended as protection against corrosive attack, e.g. caused by corrosive chemicals and/or variable climatic conditions (rain/salt air, sea water, high humidity). Furthermore, the packaging is intended for temporary usage only and not applicable for long-term storage of clad plates.

Clad plates are being arranged in single or multiple bundles for packing. Actual grouping is being performed depending on individual plate size, resulting bundle weights and limitations from lifting gear and means of transport. Grouped clad plate bundles may be fixated with steel strapping according to specific packaging instruction.

LOADING, UNLOADING AND STORAGE OF CLAD PLATES

In general, clad plates have to be handled and stored in a proper way to avoid damage of material's surface or negative impacts on the plate's evenness. Following conditions have to be fulfilled to preserve perfect condition of the product.

- » Clad plates require covered transport in general in order to avoid exposure to variable climatic conditions (e.g. rain/salt air, sea water, high humidity), which could result in corrosive attack. Furthermore clad plates should be unloaded and stored in covered areas.

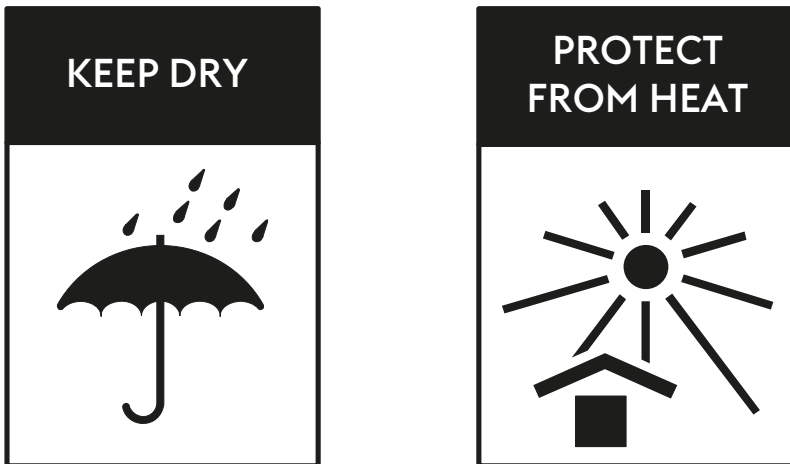

Figure 1: Only covered transport and storage

- » Storage area for clad plates should be on an even and hard surface.

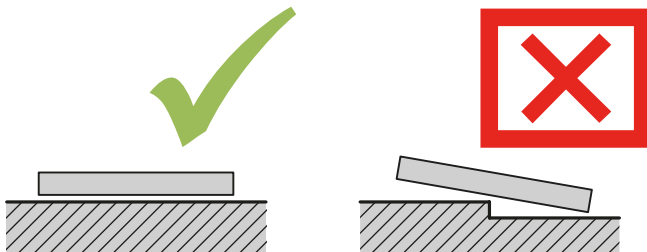

Figure 2: Even and hard storage area

- » For handling of packed clad plates at the terminal, cranes equipped with load magnets, clamps/hooks or lifting belts are recommended. The use of crowbars or pincer bars is strictly prohibited as well as the use of chains or cables in direct contact with the plate surface/plate edge. The maximum rated load for the lifting gear must be known.

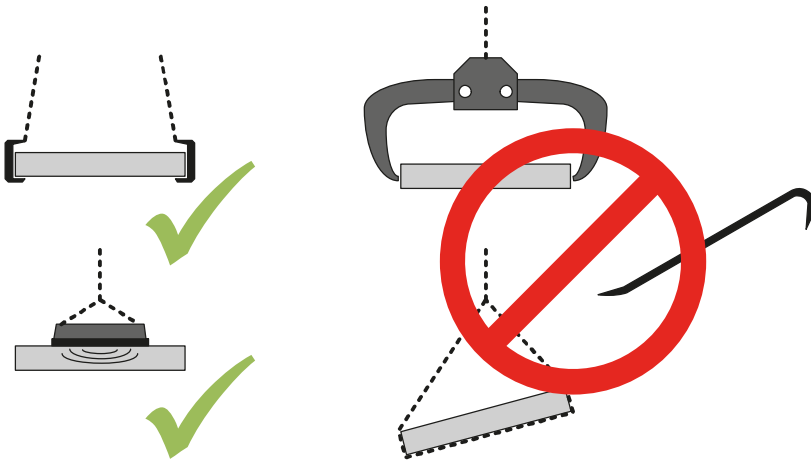

Figure 3: Suitable equipment for handling of clad plates

- » The steel strapping of bundles is only intended for temporary fixation of bundles and the used packaging materials. When handling plates with clamps/hooks, the lowest plate in the bundle has to be attached. When plates are handled with load magnets, sufficient field penetration of the lowest plate has to be ensured.

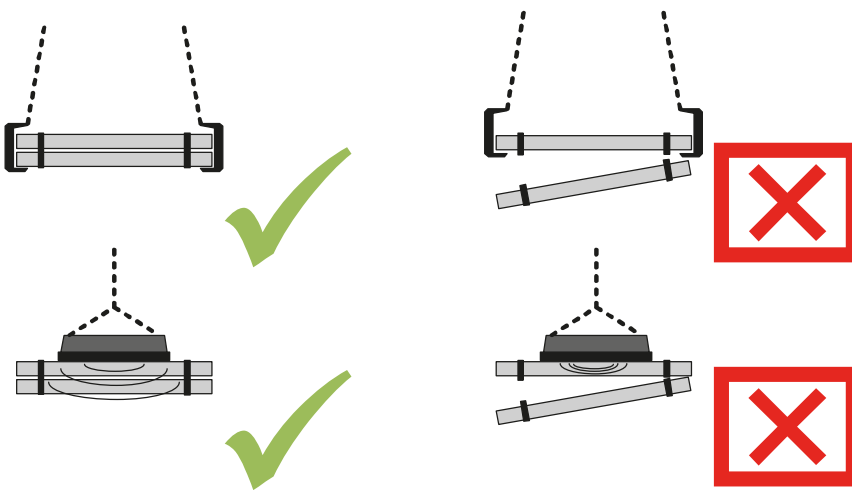

Figure 4: Fixation of lowest plate when loading multiple plate bundles

- » The use of forklift trucks for handling should be avoided but is possible as long as the whole bundled clad plate unit can be picked up. It is prohibited to separate single units with forks.

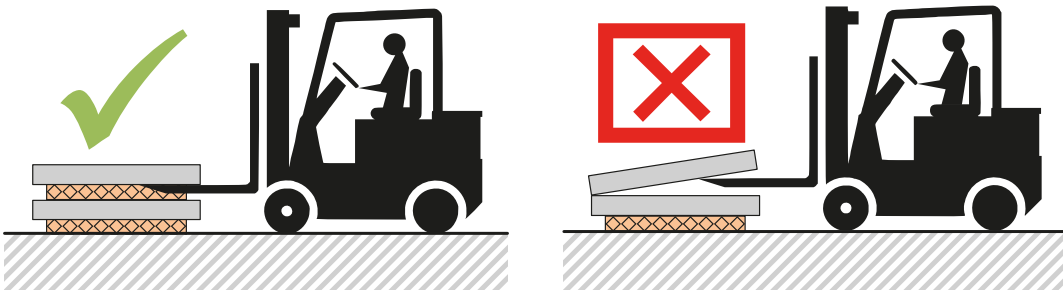

Figure 5: No separation of flat-lying clad plate bundles within a stack with forklift

- » When storing and loading clad plate bundles, flat unit-on-unit storage is not recommended. Especially when bundles are handled with forklifts or cranes using clamps/hooks, sufficient clearance between each plate bundle has to be ensured by placing appropriate supporting timbers. Supporting timbers should be placed between each bundle and on the ground floor.

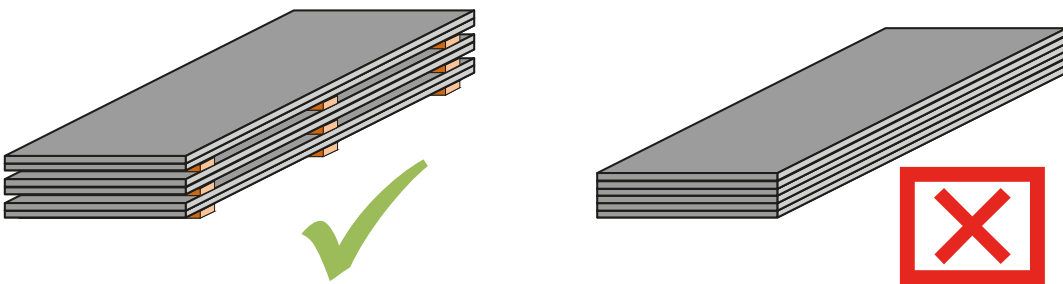

Figure 6: Use of supporting timbers to ensure clearance for loading

- » When supporting timbers are placed between clad plate bundles, these have to be arranged in exact vertical alignment all the way from the bottom up in order to ensure evenness of the plates.

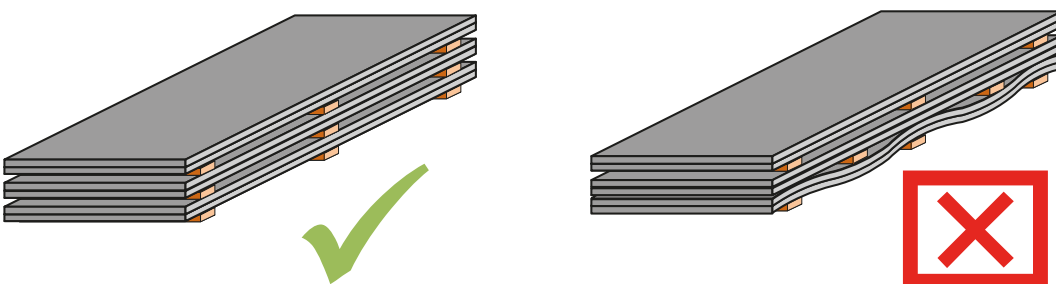

Figure 7: Correct alignment of supporting timbers between plate bundles

- » When supporting timbers are placed between clad plate bundles, these must be fitted with the wider side against the plate.

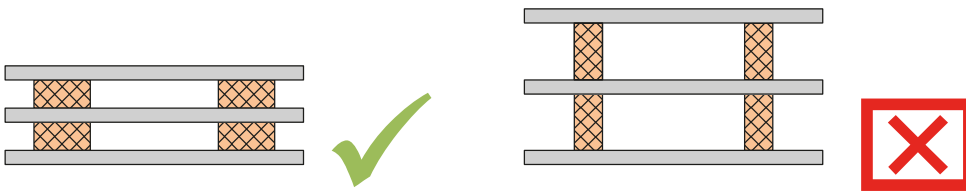

Figure 8: Correct fitting of supporting timbers between plate bundles

- » Supporting timbers must be placed transversally to the plates. Recommended distance between timbers is max. 2.000 mm.

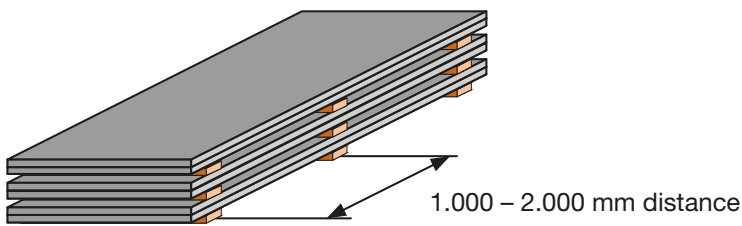

Figure 9: Distance between transversally placed supporting timbers

- » Number and dimension of supporting timbers used, result from customer's requirement or voestalpine's standard. If bundles cannot be handled at the terminal with the timbers provided by voestalpine, the terminal shall contact the FOB-agent in order to announce its requirements (e.g. due to the size of forks).
- » Bundled clad plate units must not be opened by cargo forwarding companies. Steel strapping must not be cut and protective films must not be cut or damaged.

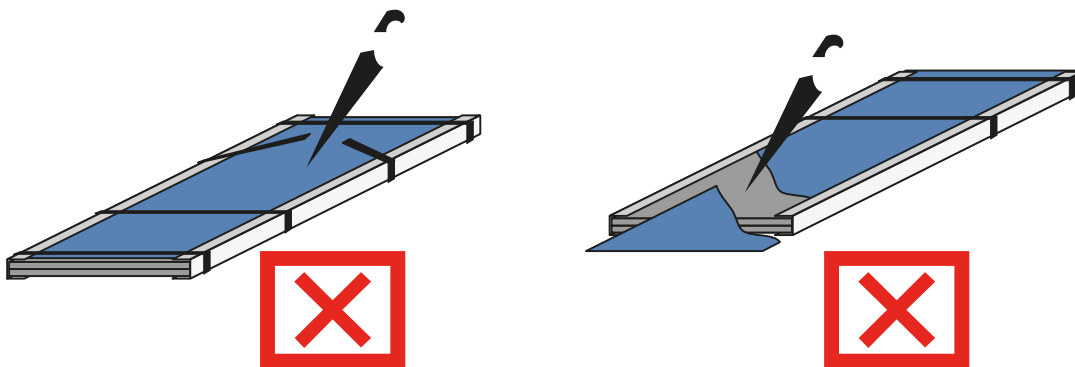

Figure 10: No opening of clad plate bundles; No cutting of protective packaging materials

- » Contact with corrosive substances (e.g. chlorides, halogens, etc.) has to be prevented in general. Please note that some permanent markers can contain such corrosion causing chemicals.



Figure 11: Avoid any contact with corrosive substances

- » The packaging is intended for temporary usage only and not applicable for long-term storage. Some packaging materials are subject to aging thus resulting in changed material properties.
- » In case adhesive LDPE foil is used for protection of the grinded clad surface, it must be removed within 6 month after delivery at the latest in order to ensure desired protective properties and easy peel-off. Exposure to direct sunlight or UV radiation will shorten the time, the film can be removed easily. For optimal peel-off, the temperature should be not less than 10 °C / 50 °F. At temperature below minus 10 °C / 14 °F the foil will get brittle thus losing its protective function.

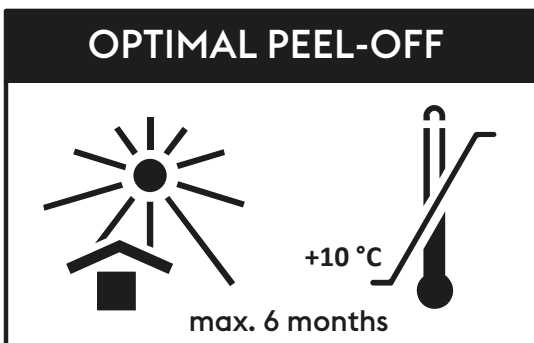

Figure 12: Conditions for optimal adhesive LDPE foil peel-off

General information for loaders and truck drivers

Loaders and truck drivers will find a checklist lorry-sheet attached for the correct transport and handling of clad plates. Each driver will get this checklist from the loading operator before they are loading clad plates by truck. This sheet should show, how the truck drivers should handle and manipulate clad plates before/ during/after the transport and what they have to consider in this case.

NON-CONFORMANCE HANDLING

For the unlikely case that non-conformances are determined for arriving material, please consider following guidelines:

- » In case that clad plate bundles arriving at the terminal are not conform to the dispatch note (e.g. different number of plate bundles, different sizes of units, different data on individual dispatch labels of bundles), the cargo-forwarding company has to inform LogServ/voestalpine immediately.
- » In case plate bundles arriving at the terminal show any visual damage, following procedure has to be followed by the cargo-forwarding agent:
 1. Contact the LogServ/voestalpine-representative to clarify the extent and nature of the damage.
 2. Before unloading affected materials, ensure damages are properly documented and have been acknowledged by the carrier (truck driver, bargemen or railway representative).

In case of ambiguities regarding the above stated requirements, please contact LogServ/voestalpine for further clarification!

The information and product properties contained in this printed material are non-binding and serve the sole purpose of technical orientation. They do not replace individual advisory services provided by our sales and customer service teams. The product information and characteristics set forth herein shall not be considered as guaranteed properties unless explicitly stipulated in a separate contractual agreement. For this reason, voestalpine shall not grant any warranty nor be held liable for properties and/or specifications other than those subject to explicit agreement. This also applies to the suitability and applicability of products for certain applications as well as to the further processing of materials into final products. All application risks and suitability risks shall be borne by the customer. The General Terms of Sale for Goods and Services of the voestalpine Steel Division shall apply to all materials supplied by the voestalpine Steel Division and can be accessed using the following link: www.voestalpine.com/stahl/en/The-Steel-Division/General-Terms-of-Sale

Technical changes are reserved. Errors and misprints are excepted. No part of this publication may be reprinted without explicit written permission by voestalpine Grobblech GmbH.

CHECKLISTE LKW – TAFEL / PLATTIERTE BLECHE TRANSPORT

CHECKLIST LORRY – SHEET / CLAD SHEET TRANSPORT



Versandauftrags Nr.
Shipping order no.

nach Beladung des LKW in Linz / after loading lorry in Linz

	ja/yes	nein/no	Bemerkung / Comment:
1. Ladefläche sauber, trocken und gedeckte Ladung Cargo area clean, dry and covered cargo	<input type="checkbox"/>	<input type="checkbox"/>	
2a. Unterlegmatten und Unterleghölzer unter und deckungsgleich zwischen den Blechen Support mats and wooden supports under and congruent between the sheets	<input type="checkbox"/>	<input type="checkbox"/>	
2b. Antritsmatten min. 10 mm zwischen plattierte Bleche und Gurtratsche legen um Eindrücke zu vermeiden Place anti-slip mats at least 10 mm between the clad sheet metal and belt ratchet to avoid impressions	<input type="checkbox"/>	<input type="checkbox"/>	
3. Mischladung mit Grobbleche (Plattierte Bleche oben laden) Mixed load (clad sheets load on top)	<input type="checkbox"/>	<input type="checkbox"/>	
4. Tafelbleche nach VDI Richtlinie gesichert Sheet metal secured according to VDI guidelines	<input type="checkbox"/>	<input type="checkbox"/>	
5. Richtlinien für Schrägverladung eingehalten (wenn Schrägverladung) Guidelines for inclined loading complied with (if inclined loading)	<input type="checkbox"/>	<input type="checkbox"/>	
6. Andere Gegenstände auf den Blechen gelagert (Fremdmaterial, Paletten, Ladungssicherungsmittel usw.) Other items stored on sheet metal (Foreign material, pallets, load securing equipment, etc.)	<input type="checkbox"/>	<input type="checkbox"/>	
7. Verpackung beschädigt / verschmutzt packaging damaged / dirty Wenn ja, Freigabe durch HTP/GBW: If yes, approval by HTP/GBW	<input type="checkbox"/>	<input type="checkbox"/>	
8. Verschmutzung am Material und Verpackung Contamination on the material and packaging Wenn ja, Freigabe durch HTP/GBW: If yes, approval by HTP/GBW	<input type="checkbox"/>	<input type="checkbox"/>	
9. Bilddokumentation der Beladung durchgeführt Image documentation of the loading carried out	<input type="checkbox"/>	<input type="checkbox"/>	

Datum/date:	Unterschrift Verladener / signature loader:	Unterschrift LKW Fahrer / Signature truck driver:
Aktivität/Activity: Verantwortlich / Responsible:	Checkliste ausfüllen/fill in checklist	Fahrer/driver
		Abgabe ILL / return ILL

ALLGEMEINE HINWEISE VERLADER/LKW FAHRER

General information for the loader / truck driver

» **Betreten / Begehen des Material es nur beim Öffnen und Verschließen des Verdecks erlaubt!**

Entering / walking on the material is only permitted when opening and closing the top!

» **Während des Be- oder Entladens dürfen keine Ladungssicherungsmittel (Ratschen, Ketten, Haken, ...) auf die plattierten Bleche geworfen oder gelegt werden!**

No load securing devices (ratchets, chains, hooks, ...) may be thrown or placed on the clad metal sheets during loading or unloading!

» **Bei dem gesamten Transportverlauf darf kein zusätzliches Material auf den Plattierten Blechen gelagert werden.**

No additional material may be stored on the clad sheets during the entire transport process.

» **Plattierte Bleche weisen eine geschliffene Oberfläche auf, welche sehr empfindlich gegenüber Beschädigungen ist/sind. Die werksseitige Verpackung bietet nur einen sehr eingeschränkten Schutz (primär gegen Verschmutzung), weshalb zur Vermeidung von Beschädigungen sowohl Verladung, Transport als auch Entladung mit besonderer Sorgfalt erfolgen müssen!**

Clad sheets have a ground surface, which is / are very sensitive to damage. The factory packaging offers only a very limited protection (primarily against contamination), which is why loading, transport and unloading must be carried out with particular care to avoid damage!

voestalpine

ONE STEP AHEAD.

03/2021

voestalpine Grobblech GmbH
voestalpine-Straße 3
4020 Linz, Austria
T. +43/50304/15-9440
F. +43/50304/55-9440
grobblech@voestalpine.com
www.voestalpine.com/grobblech

voestalpine

ONE STEP AHEAD.