

**SADEF**  
PROFILE SOLUTIONS

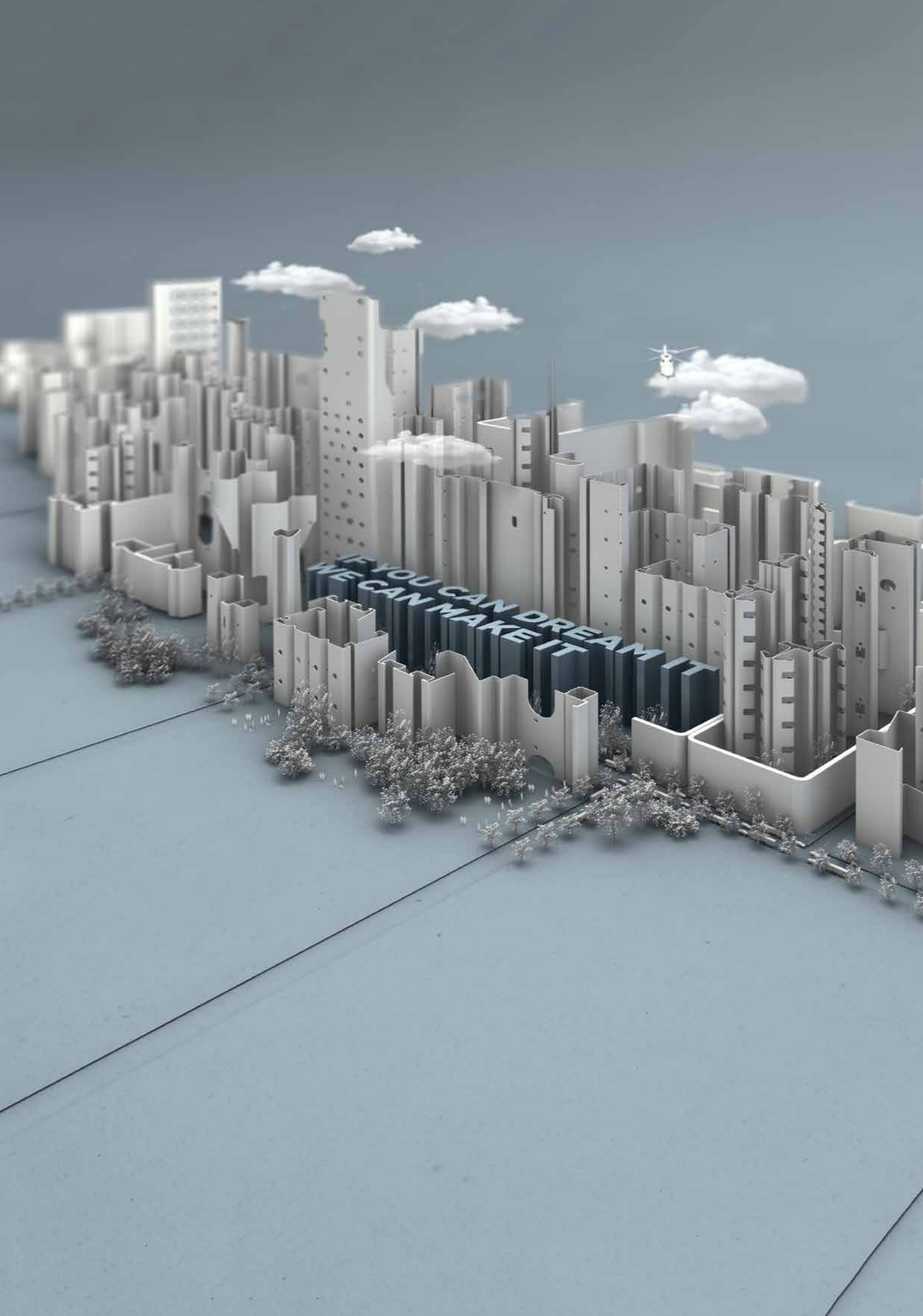

# CUSTOM MADE STEEL PROFILE SOLUTIONS



# CO-DESIGN AND PRODUCTION OF STEEL PROFILES

CO-DESIGN .....	p.10
CUSTOM ROLL FORMING .....	p.18
AUTOMOTIVE & CABS .....	p.26
BUILDING & SOLAR COMPONENTS .....	p.32
FURTHER OPERATIONS .....	p.38
QUALITY CONTROL .....	p.44
ADVANTAGES .....	p.48

# INTRODUCTION

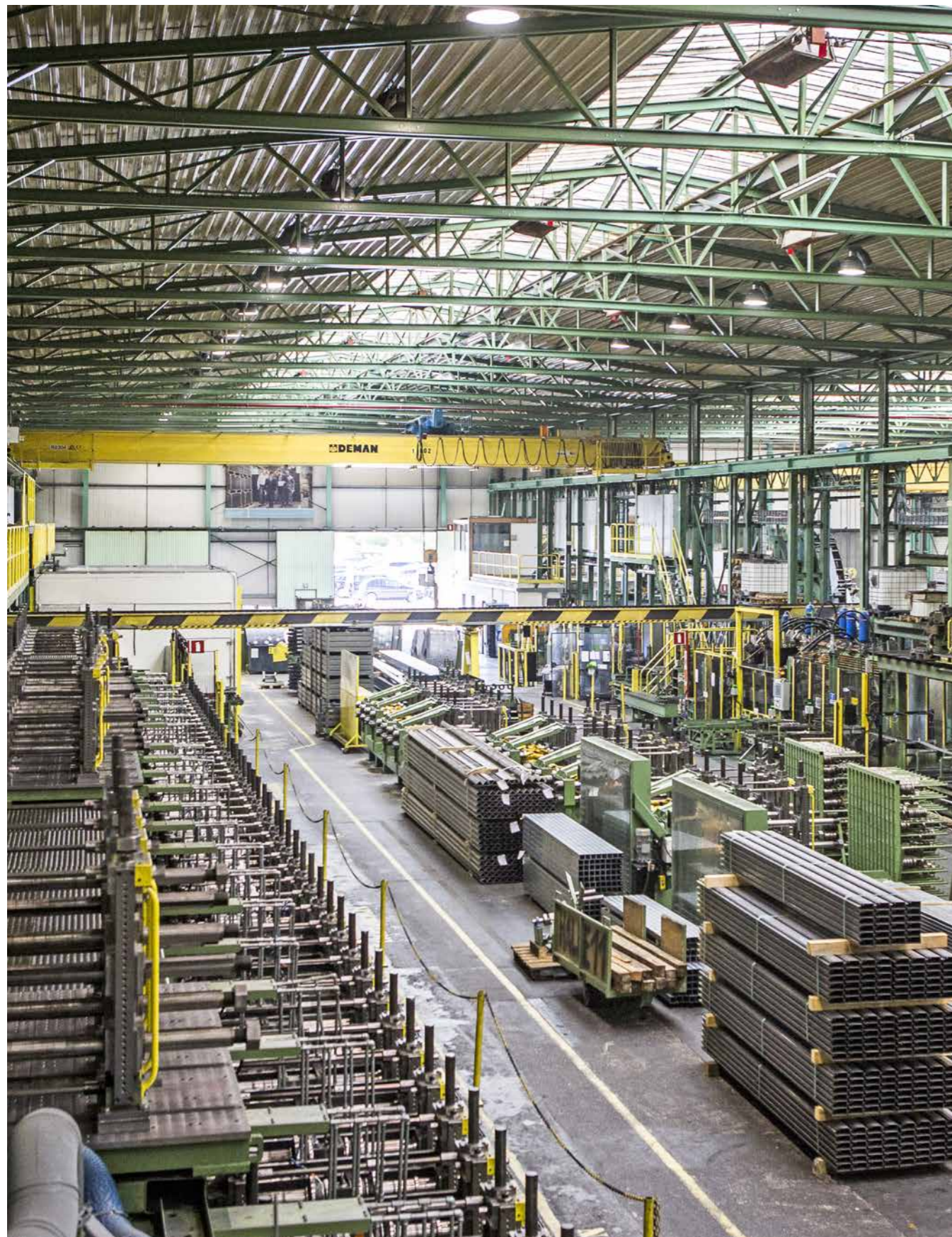

## FACTS AND FIGURES



Subsidiary of the Austrian group voestalpine

35

35 rolling mills and 200 km daily output of sections



Large range of toolings at your disposition



CE-certified solutions



Own engineering offices with over 20 engineers



Over 70 years of experience in cold roll forming



Own surface treatment (e-coat, powder-coating)



Intelligent ready-to-assemble solutions

1

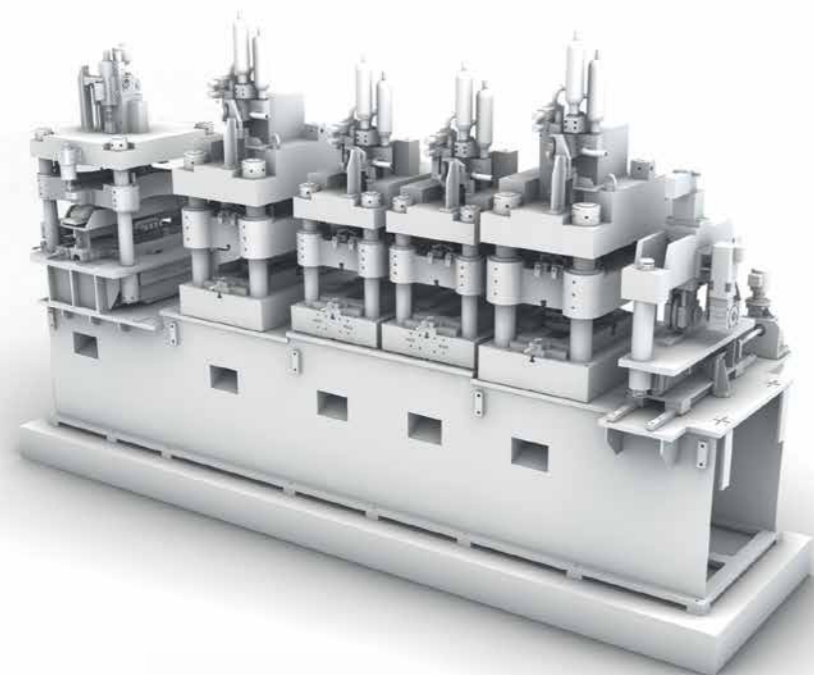

3



4

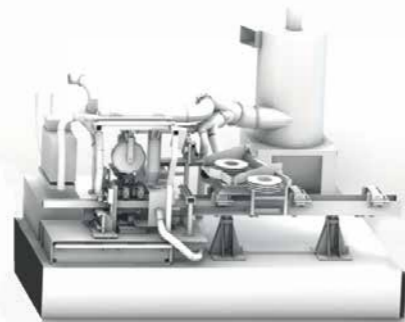

5

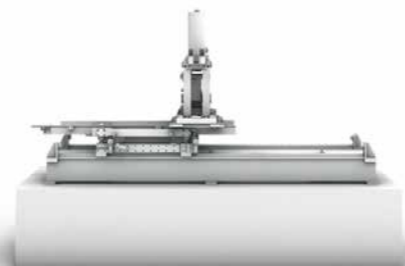

1 Pre-piercing

2 Roll forming

3 Inline-piercing

4 Inline welding

5 Cut to length

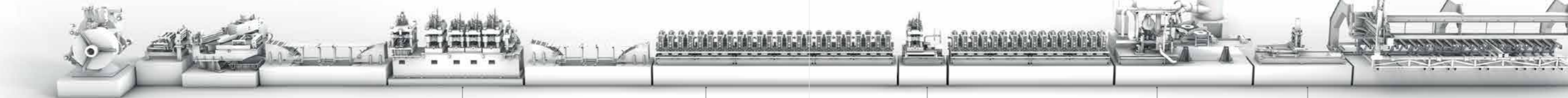

2

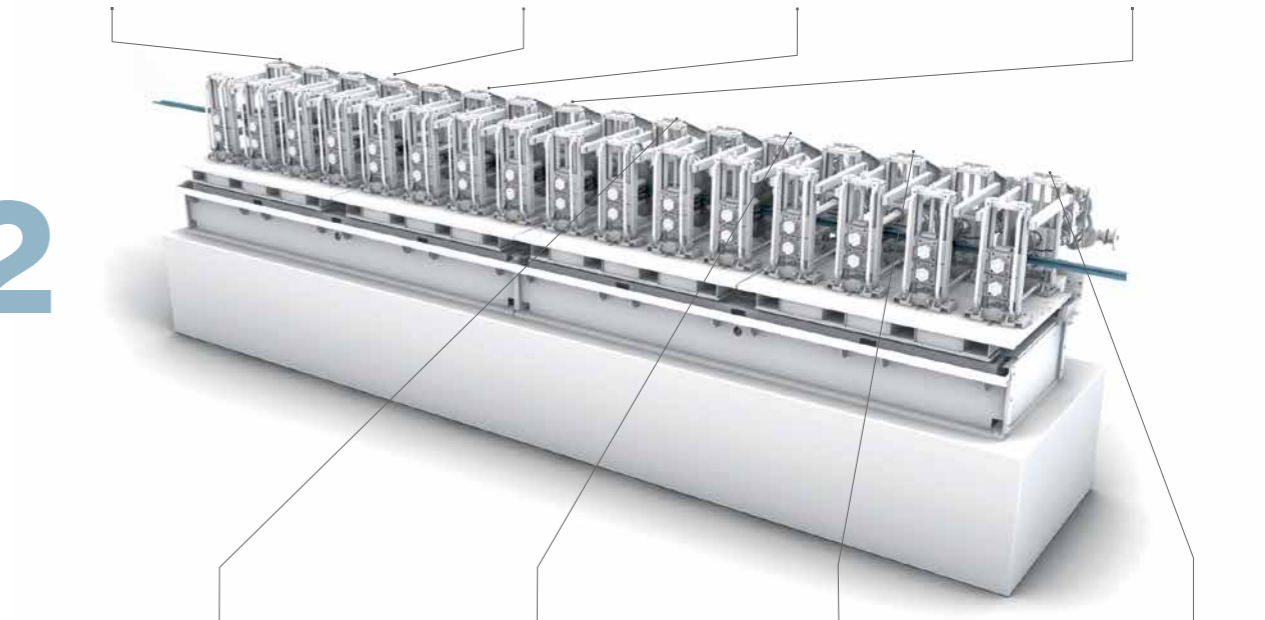
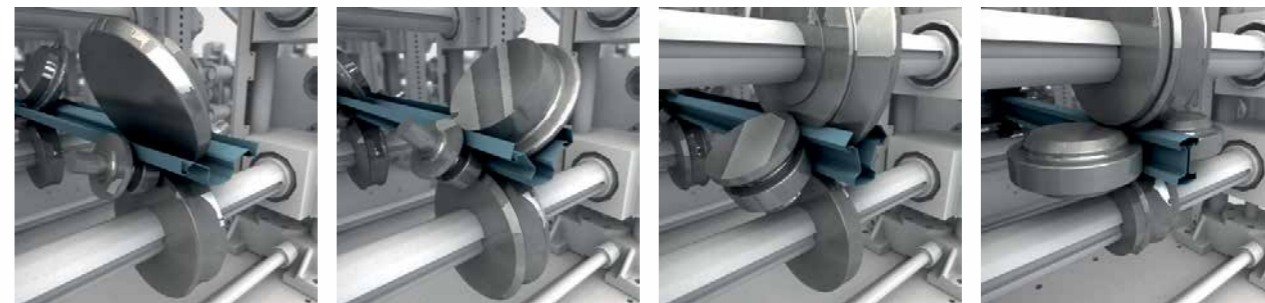
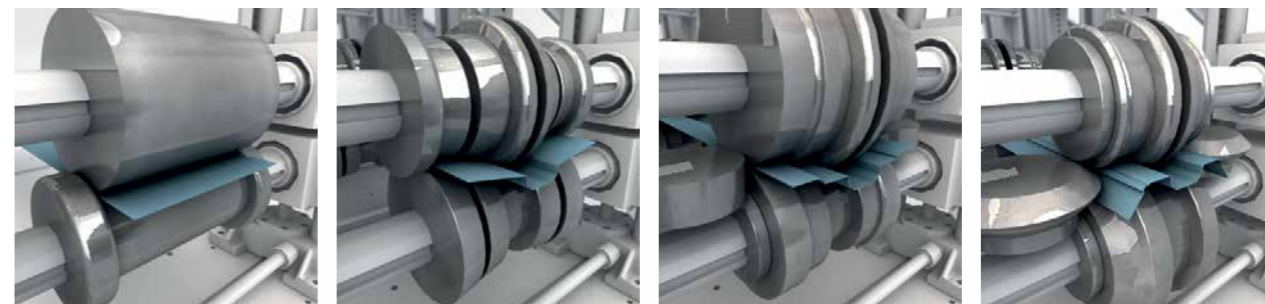

# CO-DESIGN

TAILOR-MADE DEVELOPMENT ..... p.12

TAILOR-MADE PRODUCTION ..... p.14

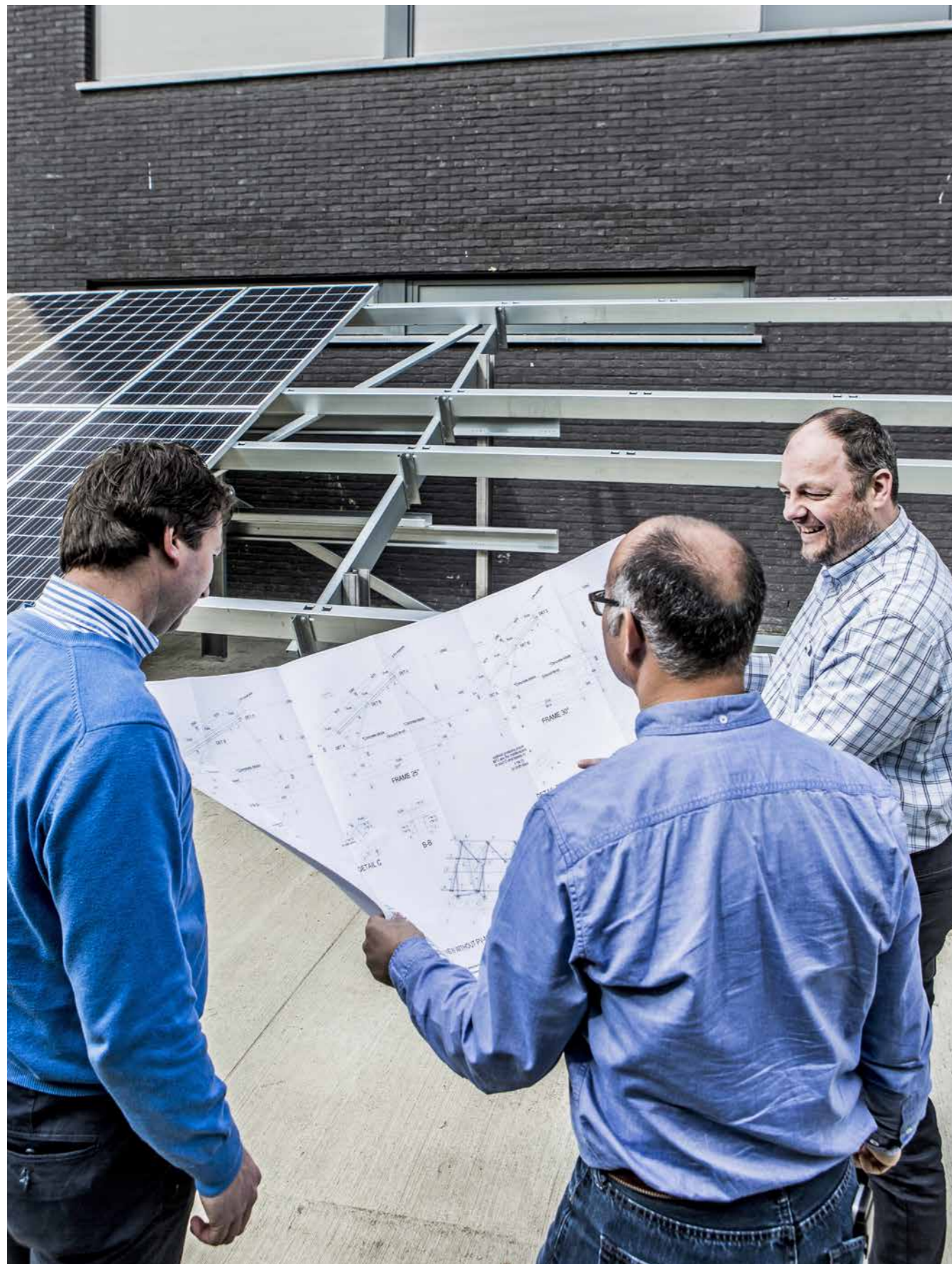

## FROM CONCEPT TO COMMERCIAL & TECHNICAL AGREEMENT

In every stage of the development, from a rough sketch to parts ready for assembly, voestalpine SadeF offers creative, innovative and cost reducing ideas and competitive concepts which will lead to an optimized solution for your application or project.

voestalpine SadeF stands for over 70 years of expertise in the design of roll formed steel sections and structures.

### CONCEPT



**1** Customer Concept



**2** Co-engineering:  
optimisation of customer need



**3** Commercial and technical agreement



**4** Tooling engineering



**5** Prototype and approval by customer

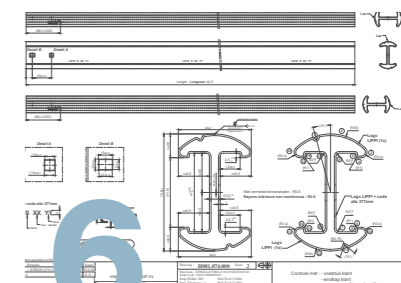

**6** Production drawing

### PRODUCTION DRAWING

# IF YOU CAN DREAM IT, WE CAN MAKE IT!



## FROM PRODUCTION DRAWING TO ROLL FORMING & SUPPLY

For each steel section that has been developed by voestalpine Sadef and its customer, we have the appropriate production means to go from production drawing to delivery.

voestalpine Sadef also has dedicated and flexible production lines for building components which allow fast delivery without any tooling investment by the customer.

High tech roll forming lines are using strips from 20 mm up to 1100 mm width and between 0.4 mm and 11 mm thickness in various steel grades: hot rolled and cold rolled, pickled, pre-painted, pre-galvanised and stainless. Sections can be open or welded, pre- or post-pierced.

### TAILOR-MADE PRODUCTION



7 Roll Forming



8 Further manipulation



9 Quality control

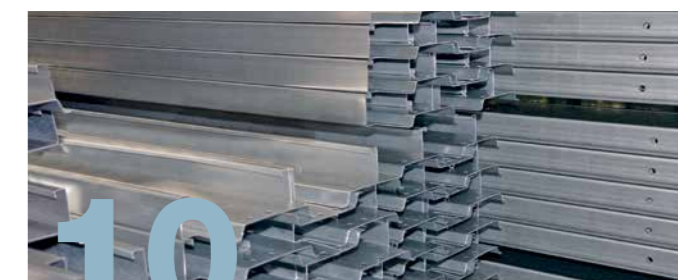

10 Packing & supply

### AFTERSALES & OPTIMISATION



# SADEF IS EVERYWHERE

Indoors or outdoors. At home or at work. The voestalpine SadeF products are found everywhere. Wherever you are, there is always a profile or component near you. Without realising it, voestalpine SadeF is omnipresent in your daily life. This illustration is the proof.

- 01 Frame for a bed
- 02 Reinforcement profiles for windows and doors
- 03 Retention walls in the bathroom
- 04 Construction for solar panels
- 05 Forklift cab
- 06 Crane cab
- 07 Components for a combine harvester
- 08 Safety cab components for a tractor
- 09 Sidemembers and cab structure for a truck
- 10 Fence posts
- 11 Profiles for warehouse shelving
- 12 Frame for a bus shelter
- 13 Sideboards for a trailer
- 14 Steel structure of a bus
- 15 Tram roof profiles
- 16 Complete structure for a modular unit
- 17 Steel car bumper
- 18 Sliding rails for a car seat
- 19 Cover in the boot of a car
- 20 Sideboards for a parking meter
- 21 Meccano of profiles for a hall
- 22 Parts for conveyor systems
- 23 Steel structure of a house

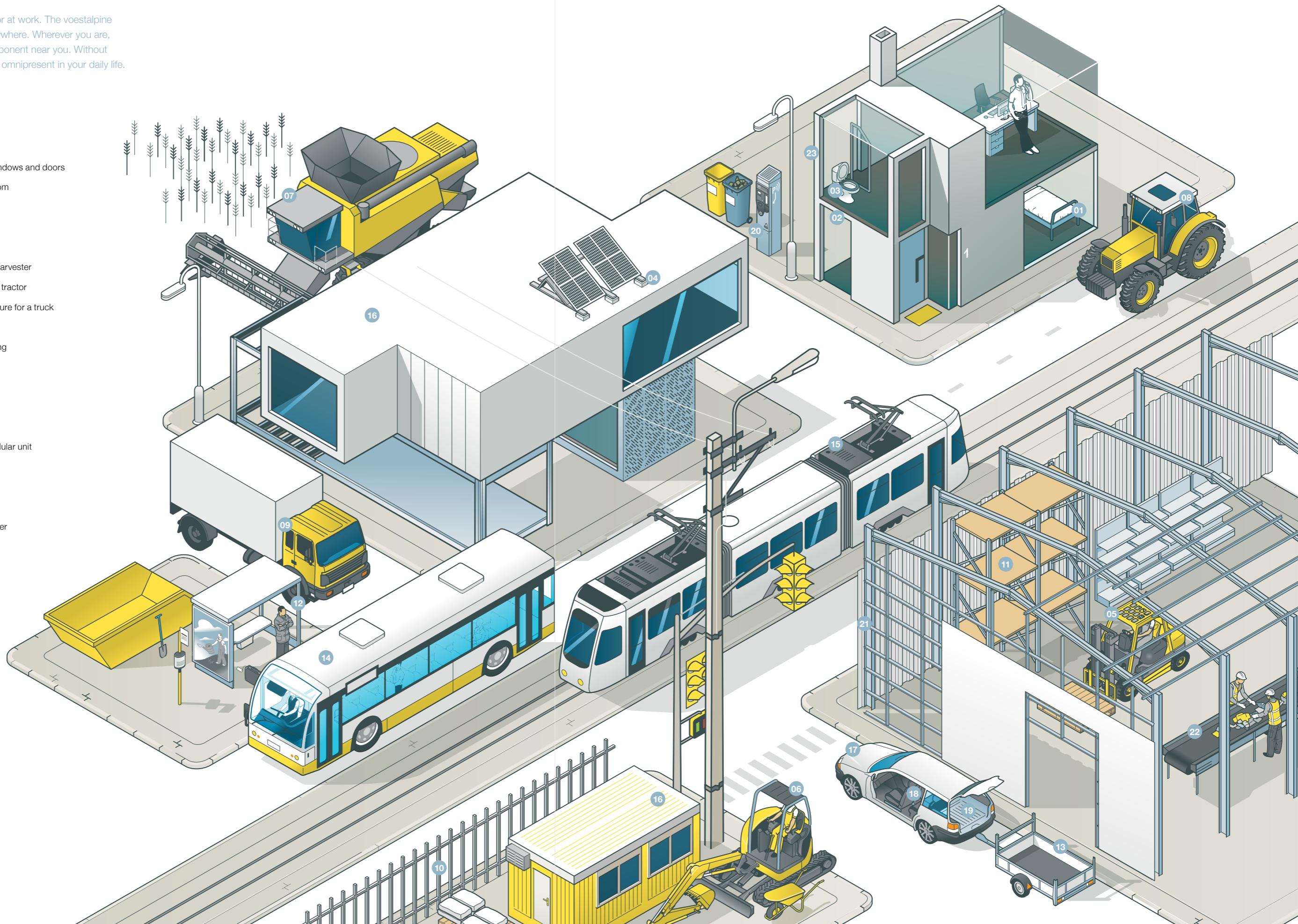

# **CUSTOM ROLL FORMING**

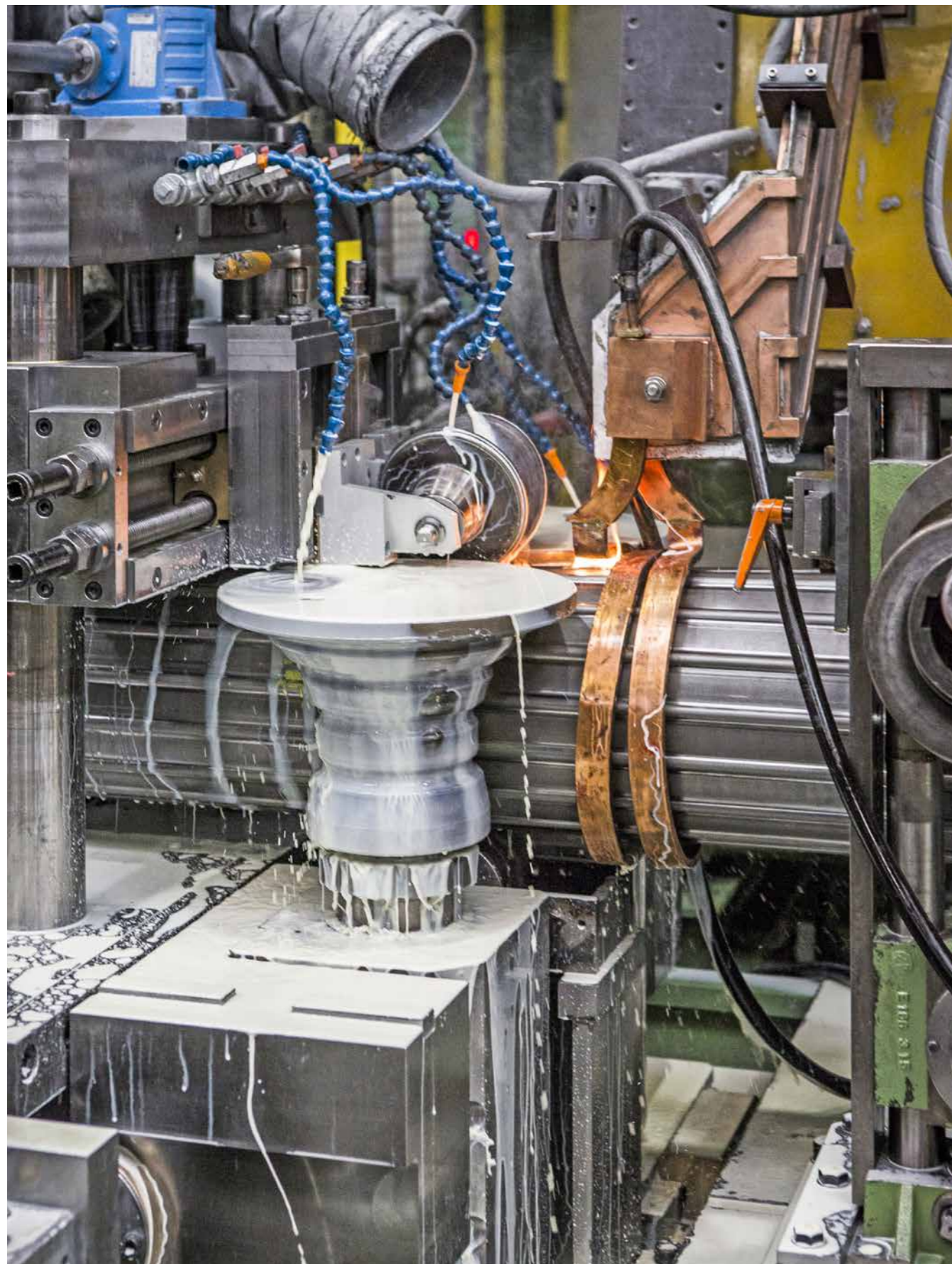

## CUSTOM ROLL FORMING

In the CRF (Custom Roll Forming) Division, the customer engineering concept is implemented in practically every customer case. The interchangeable tooling of thousands of existing section shapes allows voestalpine Sadef to supply a perfect steel section in the right material (e.g. stainless steel, pre-coated steel, pre-galvanised steel, etc.) as a ready for assembly component, and painted in your color.

Production includes pre-, mid- and post-piercing, rolling, HF-welding, laser-welding and mechanical joining.

A lot of applications allow a lighter design by adding a number of bends to the original section, enhancing the work done during cold roll forming and making the section more efficient and lighter. Torsional stiffness will further increase by welding the section continuously together over its full length. voestalpine Sadef is supplier for ready-to-assemble steel parts in a wide range of industries.

voestalpine Sadef is the perfect solutions provider for all optimisation questions that customers might have.

# APPLICATIONS ARE PRACTICALLY ENDLESS.

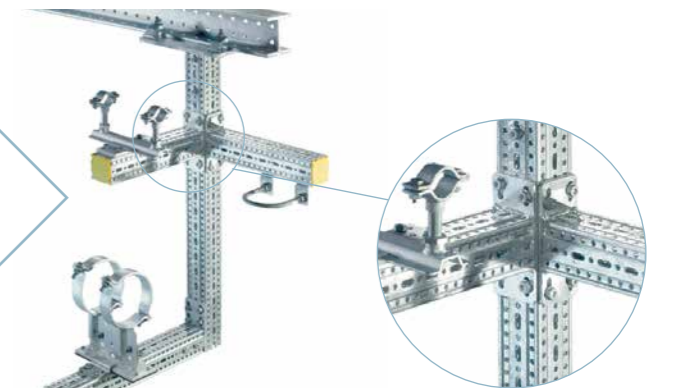

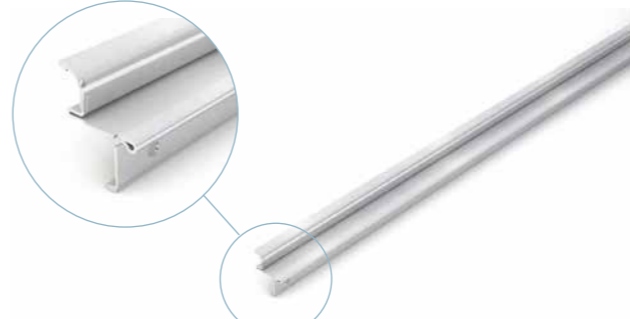

# **AUTOMOTIVE AND CABS**



## AUTOMOTIVE AND CABS

voestalpine Sadef is a leading supplier for tailor made ready for assembly frametrails to the European truck industry. Flexible production equipment guarantees a Just-in-Time or Just-in-Sequence delivery.

The surface treatment includes e-coat and/or powder coating. The possibilities offered by voestalpine Sadef in recent years in the field of roll forming persuaded car equipment manufacturers to use cold roll formed sections for the production of luggage covers, battery protectors, rails for sliding doors, bumpers, etc.

Moreover, voestalpine Sadef's automotive division meets the most stringent requirements imposed by the automotive business.

We deliver our special or standard tubes worldwide to the largest and most important safety cabin producers for agricultural or earth moving equipment applications for many years. These years of experience and our acquired know-how in this business makes us your ideal partner.

# ONE-STOP-SHOP PARTNER

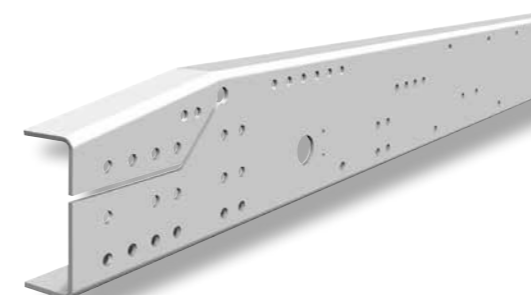
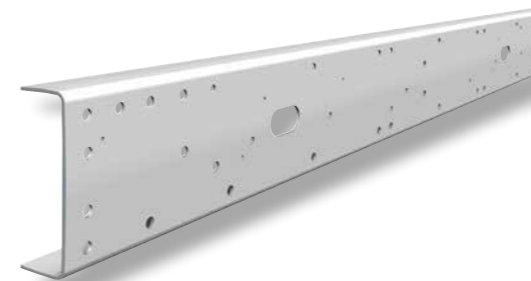
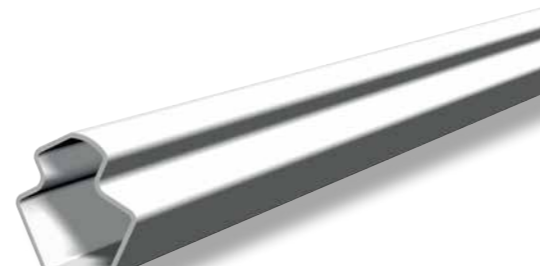
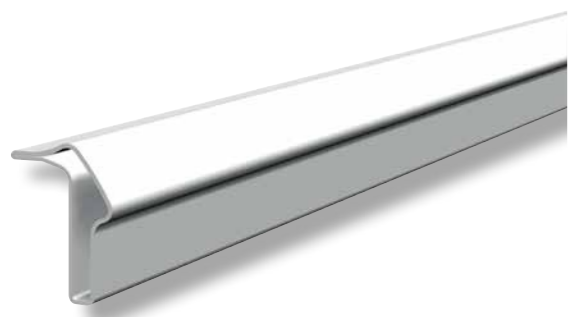
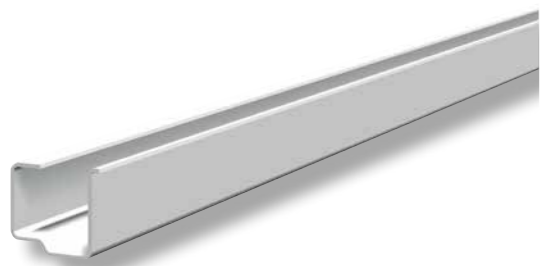



# **BUILDING & SOLAR COMPONENTS**



## BUILDING & SOLAR COMPONENTS

Fast building through pre-engineered solutions. Our design team of 20 construction engineers can calculate and optimize your specific building project.

We offer assistance in the development of building systems based on the “meccano” principle. Site delivery is made as a kit of parts, clearly coded for easy assembly.

**OUR SECTIONS ARE PROVIDED WITH THE NECESSARY HOLES AND DELIVERED JUST IN TIME ON SITE, READY FOR ASSEMBLY.**

### SIGMA & SIGMA+:

+ h: 140 - 450mm  
+ t: 1,25 - 5mm

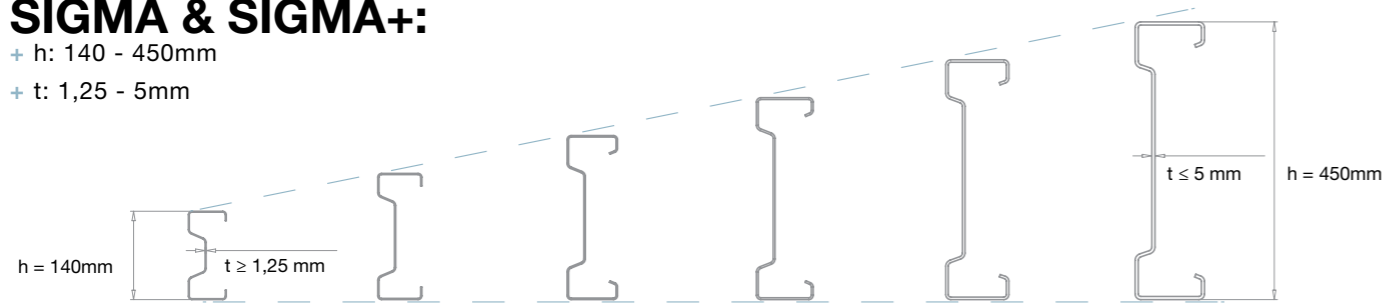

### ZED:

+ h: 140 - 450mm  
+ t: 1,0 - 5mm

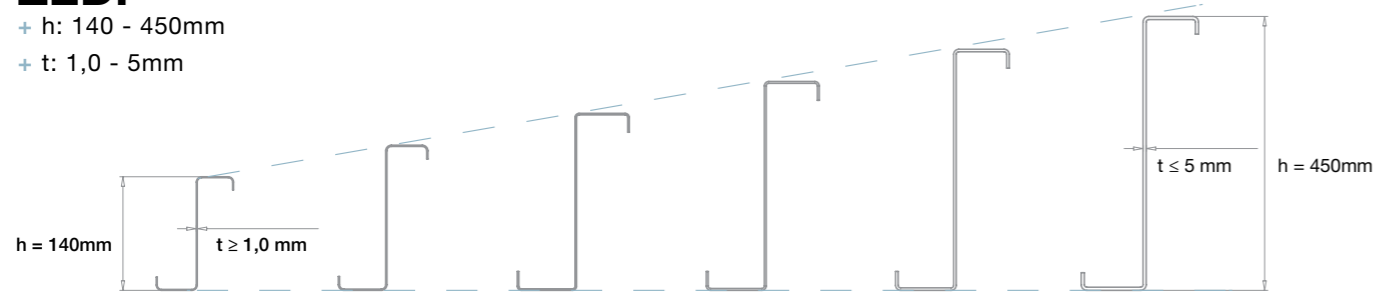

### CEE & CEE+:

+ h: 50 - 450mm  
+ t: 1,00 - 5mm



### OTHERS

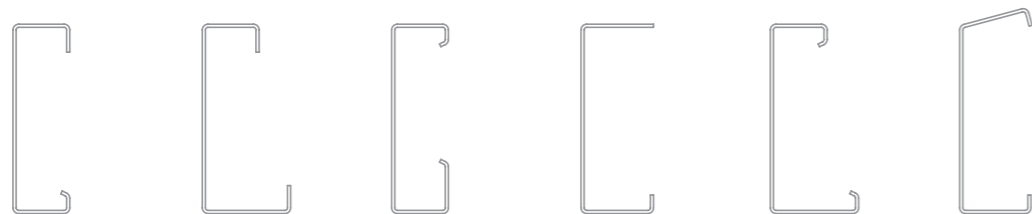

INDUSTRIAL BUILDINGS



FLOORS



MODULAR BUILDING



FLEXBUILD



GROUND MOUNT SOLAR  
STRUCTURES



ROOF TOP SOLAR  
STRUCTURES

**FURTHER  
MANIPULATION**



## FURTHER MANIPULATION

One-stop-shopping is a daily reality at voestalpine Sadef. Roll forming is followed by further manipulations: off-line piercing, cut to length tailored sections, mitre cutting, deburring, mandrel-, roll- or stretch bending, lasercutting or -piercing, flowdrilling, riveting and TIG or MIG welding.

voestalpine Sadef has a wide range of facilities for further fabrication, turning your roll formed profile into a part or component ready for assembly. Mounting inserts or nutserts, flowdrilling and threading, cut-outs and bending are operations which are done every day.

We have dedicated equipment for deepdrawing and assembly of sections by riveting, clinching or stitching. voestalpine Sadef offers a wide range of high quality surface treatment up to lengths of 12m. After a high quality pre-treatment by dipping, we can put an e-coat and/or a powder coat which guarantees you a long lasting perfect surface.

# INNOVATIVE TECHNOLOGY ENABLES US TO DELIVER HIGH QUALITY PRODUCTS.



**ROLL BENDING**



**ROLL MANDREL BENDING**



**TAILORED SECTIONS**



**INSERTS**



**ROTARY DRAW BENDING**



**FREE FORM BENDING**



**SUB ASSEMBLY WELDING**

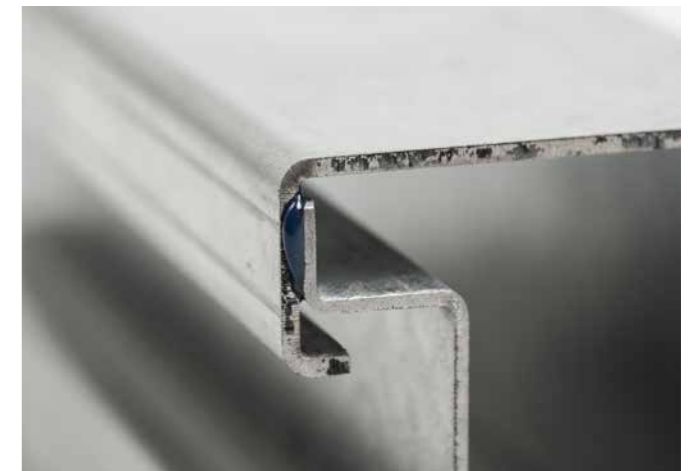

**CHEMICAL BONDING**



**CUT TO LENGHT**



**LASER CUTTING**



**SURFACE TREATMENT**



**E-COATING**

**QUALITY  
CONTROL**



## QUALITY CONTROL

Our long-term business success is the result of the outstanding quality of voestalpine SadeF products. The quality is assured by certified controlling procedures and environmental management systems.



EN 1090



ISO 9001



ISO 14001



TS 16949

**IN ORDER TO MEET THE HIGH REQUIREMENTS OF OUR CUSTOMERS, WE HAVE TAKEN ALL APPROPRIATE MEASURES AND ESTABLISHED ALL NECESSARY PROCEDURES.**



# **ADVANTAGES**

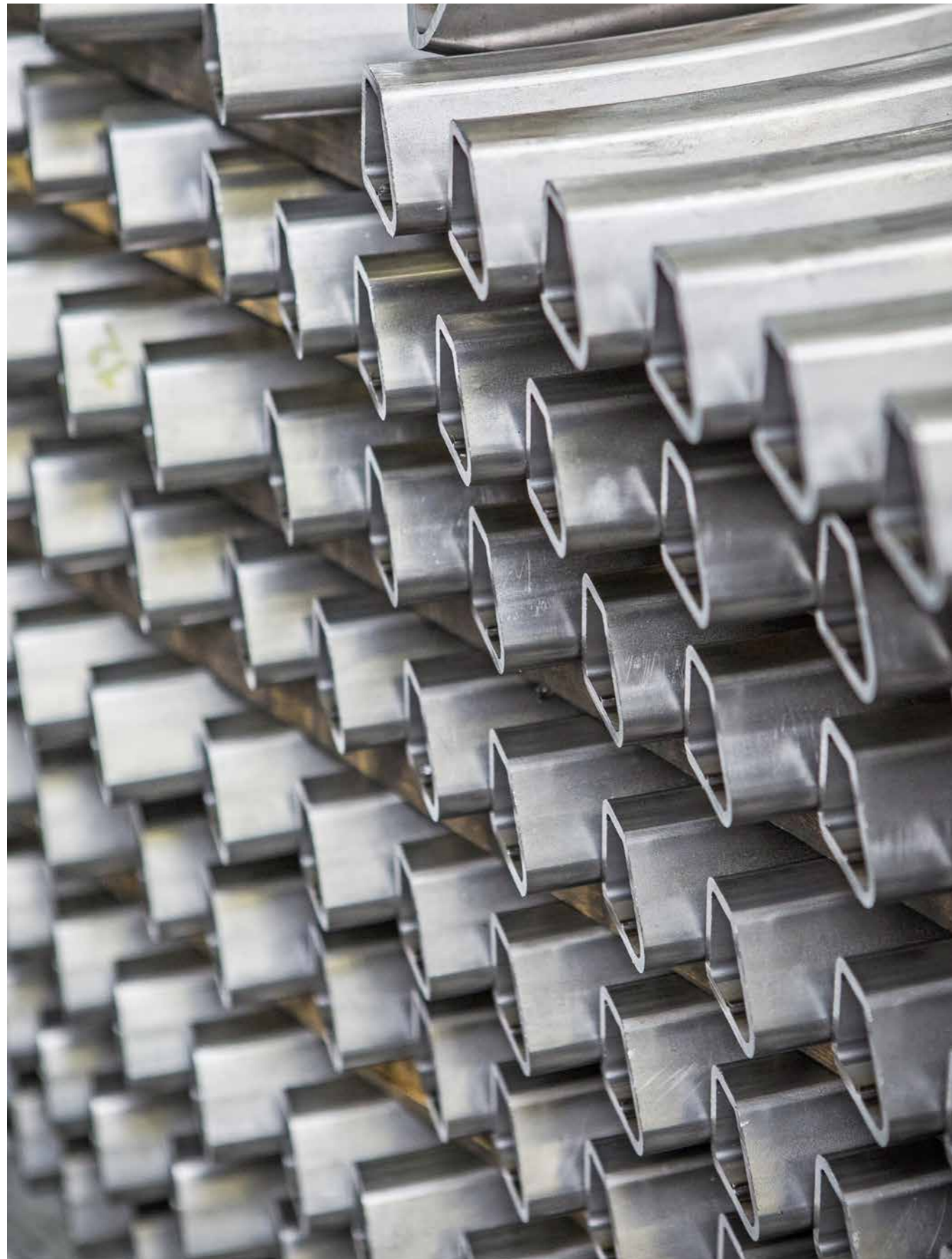

## ADVANTAGES OF VOESTALPINE SADEF STEEL SECTIONS



Reliable partner with over 70 years of expertise in roll formed steel sections



Customer Engineering: approach from sketch to finished part

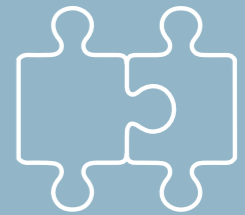

Co-engineered steel parts ready to assemble



Competitive solutions by broad possibilities in section shapes, material thickness and material quality



Flexible process of roll forming including piercing, in-line welding and cutting to length

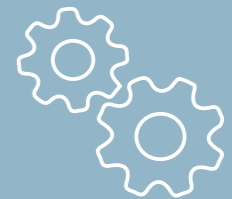

Production flexibility for big & small lot sizes



One-stop-shopping by integration of further processing



Pioneer in innovation in favour of competitive and flexible solutions



Highest standards in quality assurance

**HEADQUARTERS:**

**BELGIUM**

Bruggesteeweg 200  
8830 Hooglede-Gits, Belgium  
T. +32 51/26 12 11  
F. +32 51/26 13 01  
sadef.sales@voestalpine.com

**REPRESENTATIVE OFFICES:**

**THE NETHERLANDS**

W. Witsenplein 4  
2596 BK Den Haag, The Netherlands  
T. +31 70/324 28 02  
F. +32 51/26 16 13  
sadef.bouwnl@voestalpine.com

**FRANCE**

2, Bd Albert 1er  
94130 Nogent-s-Marne, France  
T. +33 1/43 24 60 11  
F. +33 1/43 24 60 01  
sadef.francebatiment@voestalpine.com

**GERMANY**

Frans-Tilgner-Strasse 10  
50354 Hürth, Germany  
T. +49 22/33 20 11 48  
F. +49 22/33 20 28 85  
sadef.bauprofile@voestalpine.com