

# SAFETY BARRIERS

## KREMSBARRIER RW N1

Bicycle lane barrier for pile-drivable subgrade

product specification sheet FR01/1

EG certificate of conformity: 0124-CPD-2010



tested in accordance with EN 1317-2:

containment level:	N1
impact severity level:	A
working width:	W3
system test length:	14 sections or 56,00m, without driving

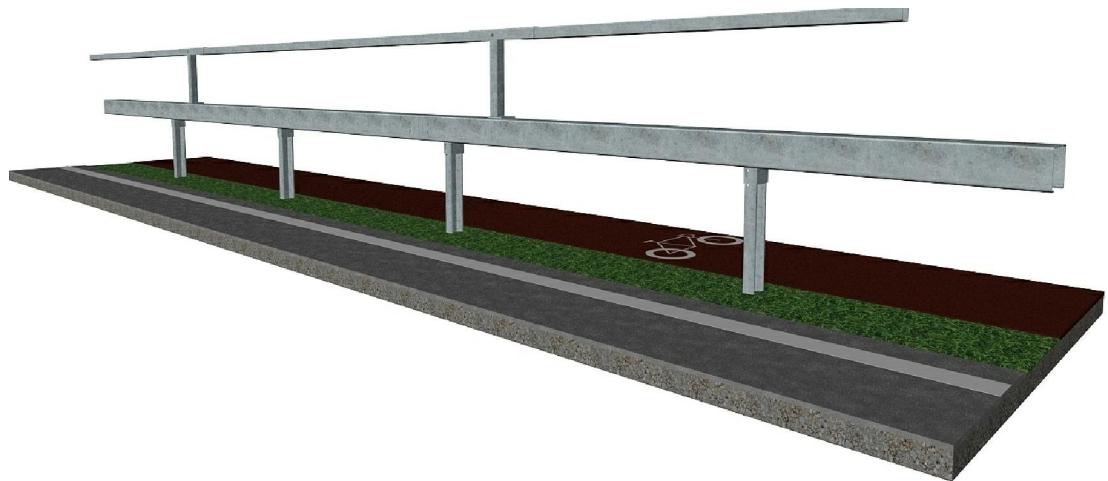

01/2015

# SAFETY BARRIERS

## KREMSBARRIER RW N1

Bicycle lane barrier for pile-drivable subgrade

product specification sheet FR01/2

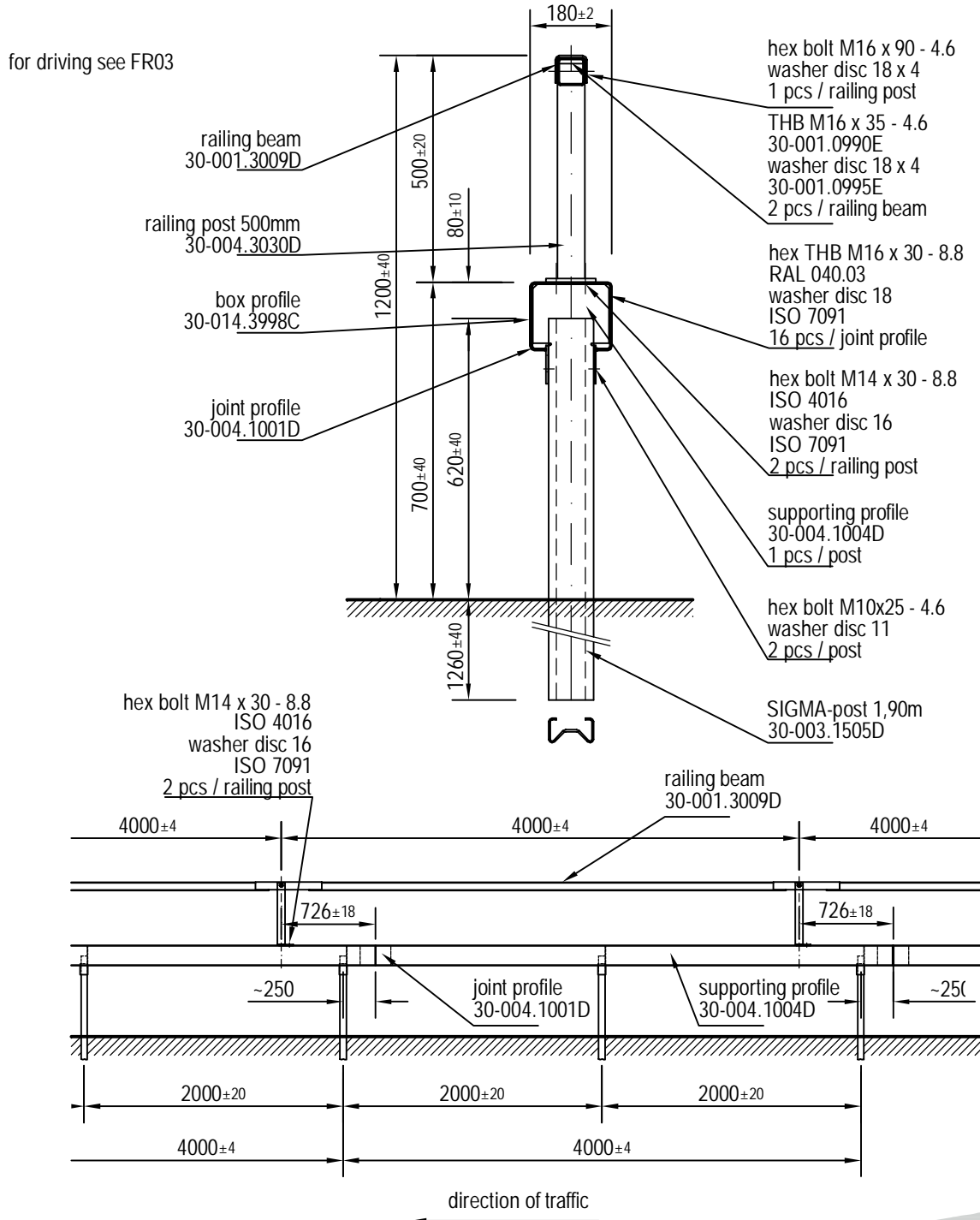

01/2015

# SAFETY BARRIERS

## KREMSBARRIER RW N1

Bicycle lane barrier for pile-drivable subgrade

product specification sheet FR01/3

installation drawing

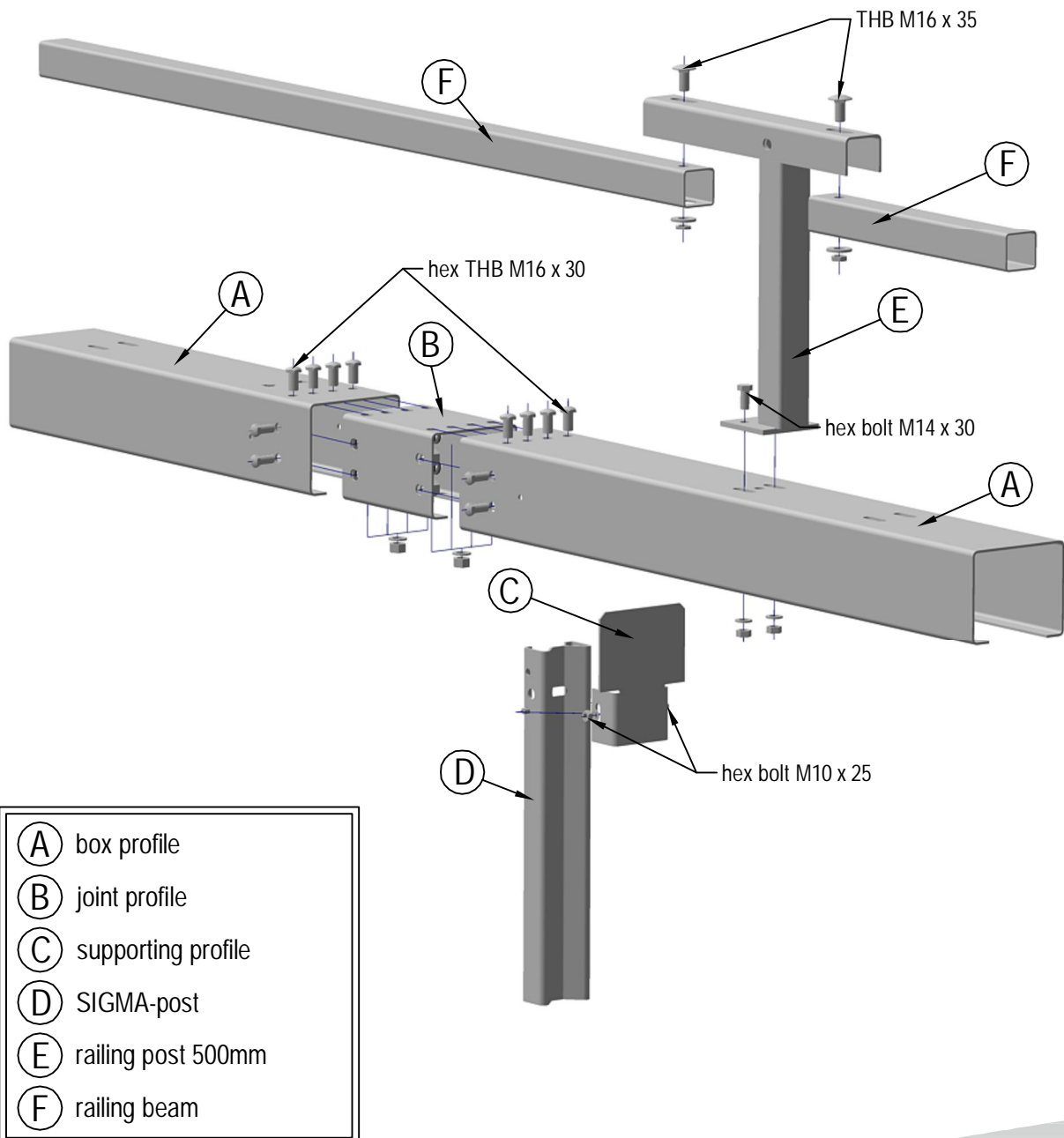

01/2015