

SAFETY BARRIERS

KREMSBARRIER 1 MH2

Restraint System for central medians and ground conditions suitable for pile driving

EG certificate of conformity: 0037-CPD-2010

product specifications Sheet C108/1



tested in accordance to EN 1317-2:

containment level:	H2
impact severity level:	B
working width:	W4
system test length:	15 sections or 57,00m, without driving



01/2015

SAFETY BARRIERS

KREMSBARRIER 1 MH2

Restraint System for central medians and ground conditions suitable for pile driving

product specifications Sheet C108/2

for driving see C110 and C111

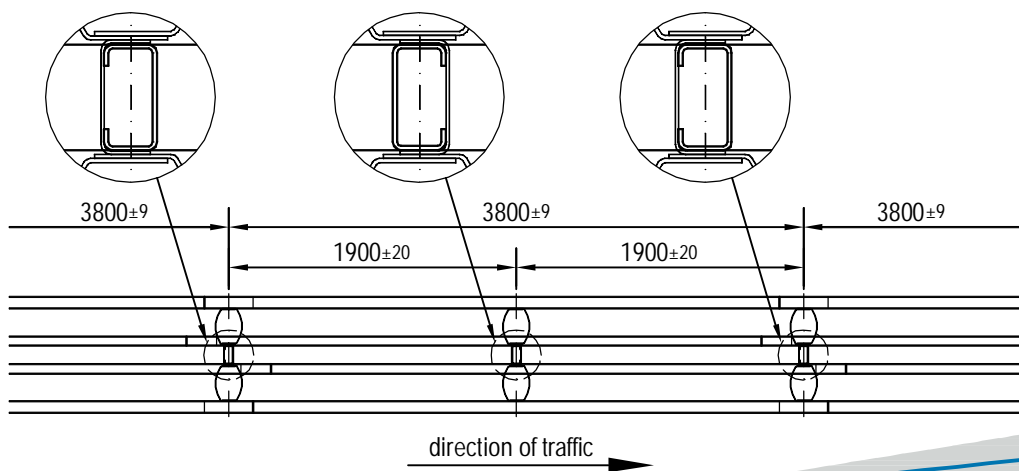
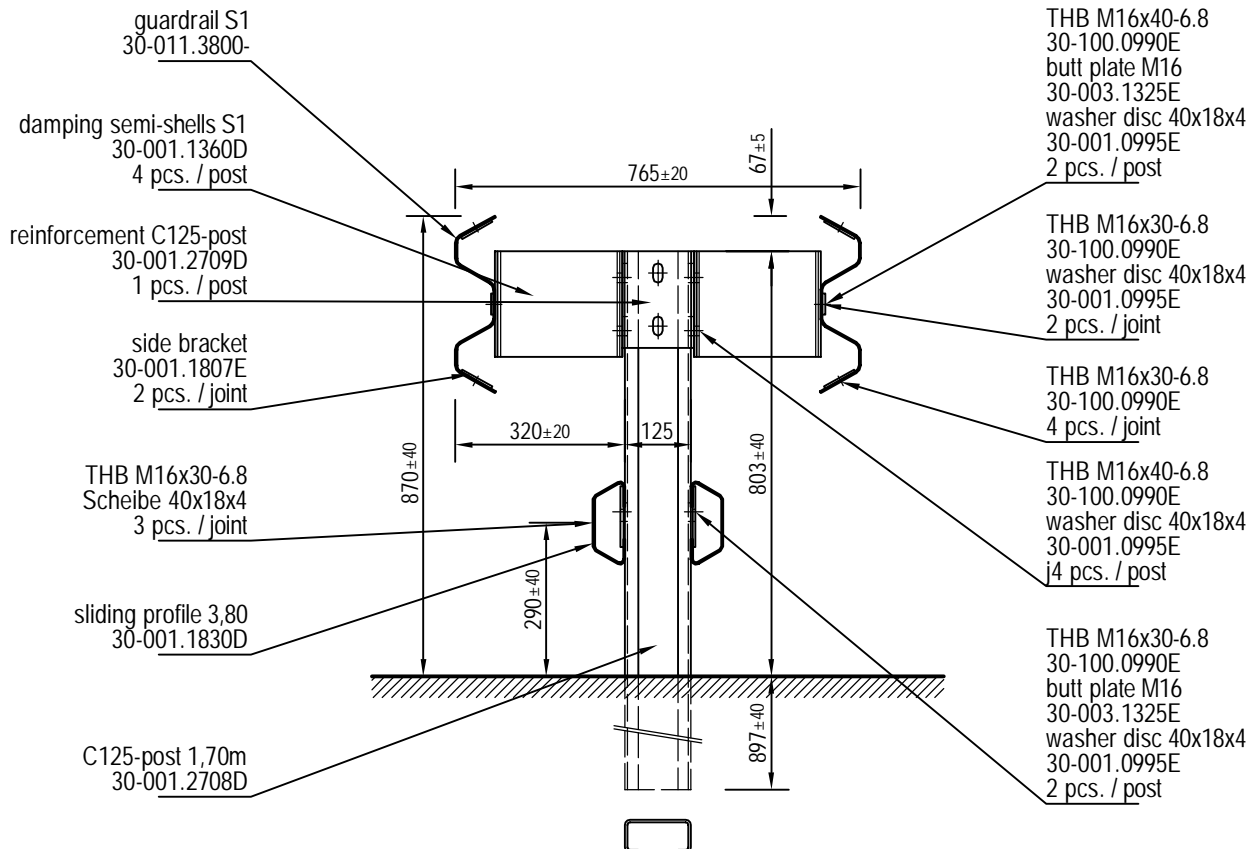

01/2015

SAFETY BARRIERS

KREMSBARRIER 1 MH2

Restraint System for central medians and ground conditions suitable for pile driving

product specifications Sheet C108/3

installation drawing

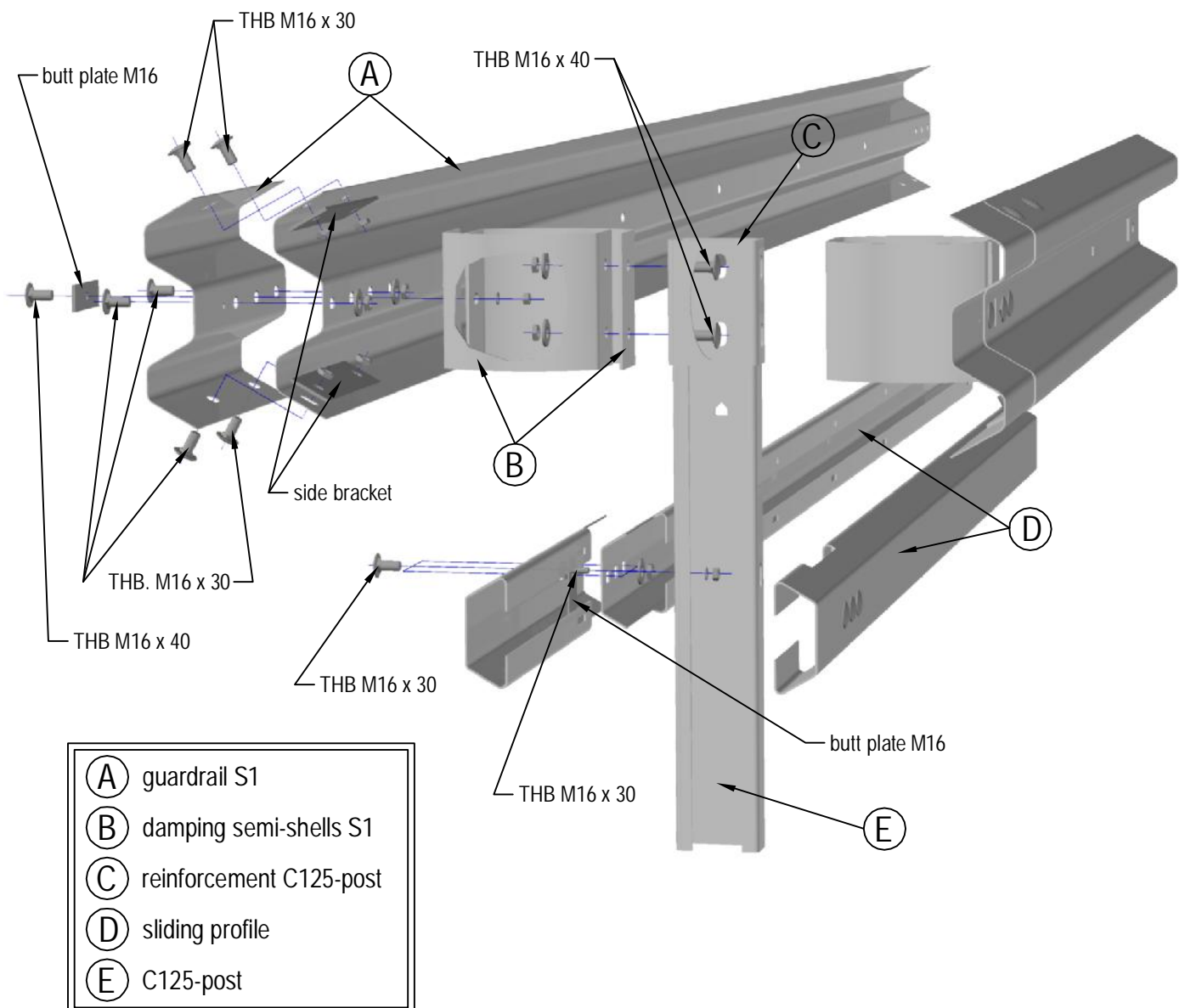

01/2015