

KREMSBARRIER 1 RH1C

auf Kunstbauten



0531-CPR-1317-0021



Technische Daten

Aufhaltestufe	H1
Anprallheftigkeitsstufe:	B
Klasse des Wirkungsbereichs:	W3
Prüflänge:	57,00 m
Systemmaß:	3,80 m
Steherabstand:	1,90 m
Systembreite:	507 mm
Systemhöhe:	750 mm
Bohrtiefe:	130 mm
GZ. BMVIT:	328.040/0002-IV/ST2/12
Detailinformationen:	www.voestalpine.com/strassensicherheit

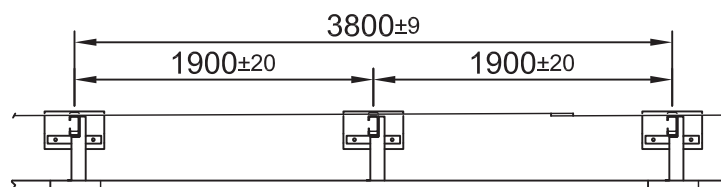
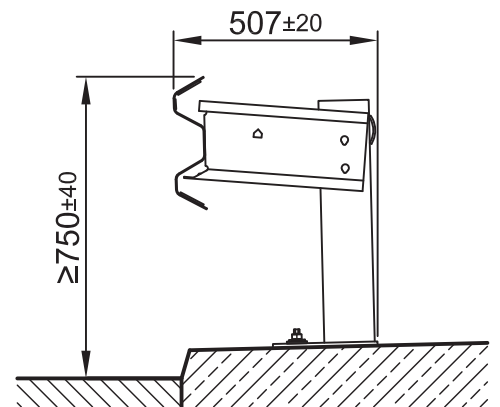

D123 - 08/2015