



# iFIX

One Part – One Click

Photovoltaic flat roof mounting system for south-facing orientation

Assembly instructions | Stand 04/2026

## ASSEMBLY INSTRUCTIONS

### iFIX SOUTH

### VERSION 2022

---

The smart substructure for photovoltaic systems  
on flat roofs





# CONTENTS

---

Features of iFIX S	4
Important planning notes	5
General assembly and safety instructions	6
Tool overview	9
Key components required	10
Assembly steps	11
Maintenance	13
Warranty	13
Accessories	14

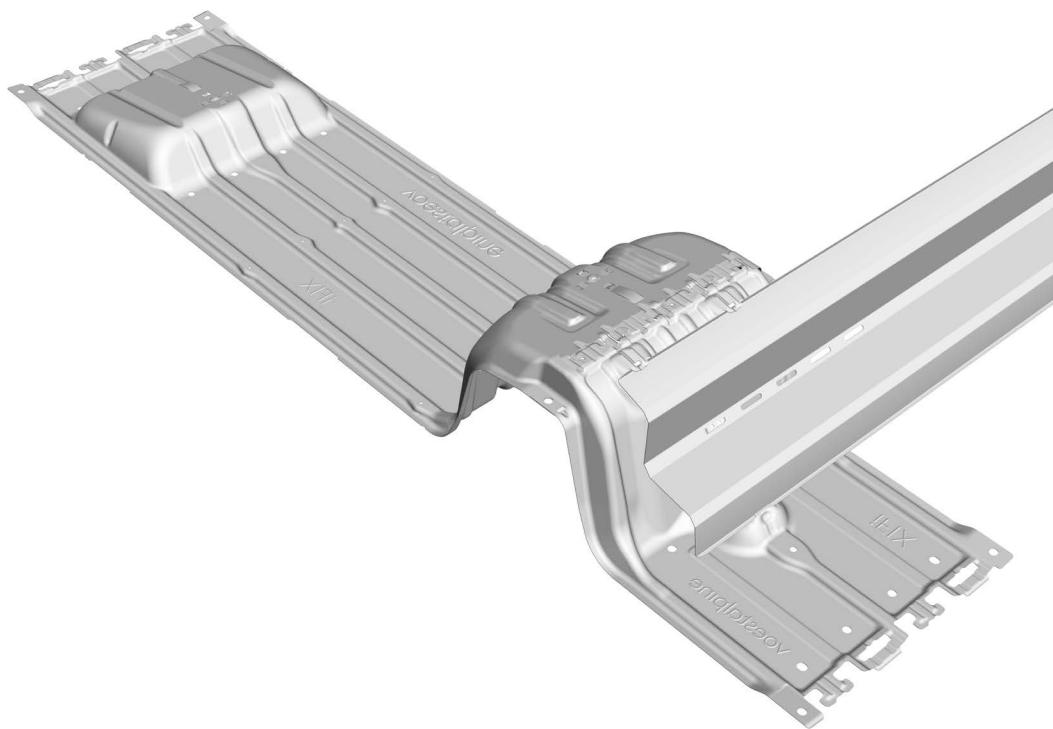

## FEATURES OF IFIX S

- » Tool-free connections between rows through a unique click-locking mechanism
- » Wind deflector can be mounted without tools by simply sliding it in
- » Fastening points designed for invisible cable routing underneath the PV modules
- » Universal centre clamps and matching end clamps with pre-fixed Allen screw for all PV module frame heights
- » Matching building protection mats are pre-assembled or can be attached to the sheet metal
- » Thermal separation between the rows is not required
- » Also suitable for use with soft roof insulation due to large footprint

## IMPORTANT PLANNING NOTES

- » iFIX S is currently suitable for buildings with a closed building front. Others upon individual inspection.
- » iFIX S can be used on all standard flat roofs with a pitch of 0 to 3° where there is no permanent standing water. Up to 5° with special on-site measures.
- » Acceptable substrates: Bitumen, plastic film, gravel, green-roof(sheet metal and others after individual testing)
- » Building height up to 50 m
- » Application areas:
  - Pressure load up to 3.8 kN/m<sup>2</sup> \*
  - Wind zone 1-3, environmental conditions up to C3
  - Gust velocity pressure up to 1,400 N/m<sup>2</sup> \*
  - With alpine supports, pressure loads of up to 5.4 kN/m<sup>2</sup>\*
- » Minimum distance iFIX S main sheet to roof edge 0.50 m. No parapet required.
- » The PV modules on the roof must be installed in blocks of at least 2, i.e., 2 PV modules in a row or next to each other..
- » Calculation of the required iFIX mounting units (1x iFIX EW+ 1x iFIX S connector) per row: Number of PV modules + 1
- » Calculation of the row length (east-west): (largest PV module length + 20 mm) x number of PV modules in series + 380 mm
- » Calculation of the field length (north-south): 1,620 mm x number of rows + 20 mm (short connector), 1,810 mm x number of rows + 20 mm (long connector).
- » Field separation due to thermal length changes: After a maximum of 15 m in the row (north-south direction), the array must be separated. This should be at least 0.5 and max. 1.3 m between the PV module ends. If the distance is greater, separate fields must be assumed in the ballast calculation. Field separation between rows (east-west direction) is required after max. 30 m. When using equipotential bonding or lightning protection accessories, regular visual inspections for thermally induced displacements must also be carried out.
- » The scope of maintenance depends on the observed displacement: With unchanged or only slight displacement up to 1 cm, an annual check is sufficient. Up to approx. 2 cm, a specific check during the next inspection is advisable. In the case of a displacement of 2-3 cm, an intermediate inspection is required after six months. If this reveals further movement of ≥ 1.5 cm, the system must be mechanically secured.
- » Applicable PV module sizes: Width: min. 990 mm, max. 1145 mm Length: min. 1650 mm, max. 2100 mm Frame height: 30–40 mm The PV module dimensions must not exceed an area of 2.17 m<sup>2</sup> and a width of 1,145 mm.
- » To ensure long-term protection of the roof cladding and the iFIX S sheets, their compatibility with one another must be checked (see assembly instructions). The underside of the iFIX EW main plate must be fitted with building protection mats, as the iFIX S Connector is only available with pre-assembled aluminium-laminated building protection mats.
- » During the design phase, it is important to check whether the roof insulation can bear the additional pressure load caused by the weight of the PV system, weighting and pressure loads. To ensure protective transfer of the system loads to the roof surface and the insulation, the EW and South sheets are offered with pre-assembled building protection mats (contact surfaces: Compact 0.112 m<sup>2</sup>, Extended 0.120 m<sup>2</sup>). The largest possible contact area can be achieved using the iFIX EW Base (without building protection mat) and the large building protection mat (iFIX Base Protect) (contact areas: Compact 0.308 m<sup>2</sup>, Extended 0.316 m<sup>2</sup>).
- » A ridge superstructure may only be added if the buckling line runs in the area of the hooking.
- » Roof surface recesses may not be covered. A field separation is required.
- » Depending on the position of the building, wind and snow loads and the height of the building, the system must be secured against lifting and moving. For this purpose, weights must be placed as weights on the designated areas according to a weighting plan individually created by the system provider.
- » The ballasting values calculated from the “iFIX-Tool” software are always made up of the weight of the substructure, the stones, the modules and wind pressure. Added to this is the mutual composite effect that only exists in the assembled state. In the semi-finished state, the installer must adequately secure the system against lifting by wind, taking into account the local weather conditions.
- » In general, care must be taken to ensure correct hooking.
- » In case disassembly is necessary, we recommend the procedure described in our disassembly video.
- » Additional accessories such as Alpine supports can be supplied optionally.

Note: Insufficient securing or lack of maintenance can lead to damage to the roof cladding, pipes and structural connections. No liability is accepted for any resulting consequential damage.

\*Depending on the area of the PV module

## GENERAL ASSEMBLY AND SAFETY INSTRUCTIONS

### STRUCTURAL ENGINEERING

Prior to installation, the client should check whether the building and roof meet the additional static requirements of the iFIX system regarding horizontal and vertical loads. The Eurocode 3 standard (DIN EN 1993) must be observed. The required ballast can be found in the system provider's individual weighting plan. The complaint plan may only be drawn up by trained personnel. The iFIX Tool calculation program for determining the weighting is available for this purpose, and is based on a wind load report and the system statics of a state-approved structural engineer.

Should the structural design of a system be carried out by the client themselves, the structure, design and stability of the construction must be carried out in accordance with:

EN 1991-1-3 Snow loads (Eurocode 1)  
EN 1991-1-4 Wind loads (Eurocode 1)

Calculations must be carried out in accordance with the latest civil engineering standards.

National and site-specific building regulations, standards and environmental protection regulations must be complied with.

### SAFETY

Work safety and accident prevention regulations, corresponding standards and regulations of the employers' liability insurance association must be adhered to!

Those are:

BGV A1 General accident prevention regulations  
BGV A3 Electrical systems and equipment  
BGV C22 Safety regulations for construction work  
DIN 18338 Roofing works  
DIN 18451 Scaffolding works

In particular, the following should be noted:

- » Wear protective clothing (especially safetyhelmet, work shoes and gloves)
- » For roof works, the regulations for working on the roof must be observed (e.g. use of: Fall protection, scaffolding with safety gear from an effective eaves height of 3 m, etc.)
- » For the entire installation process, the presence of two people is essential to ensure rapid assistance in the event of an accident.
- » Any necessary roof work must be carried out by a roofer.
- » AC/DC wiring must be carried out by an electrician. The following must be considered:

DIN VDE 0100 Part 712 – Installation of low-voltage systems and other relevant regulations applicable on site.

### MOUNTING

PV systems may only be installed and commissioned by individuals who are able to ensure that the work is carried out in accordance with the regulations due to their professional suitability (e.g. training or activity) or experience.

Please ensure that at least one copy of the assembly instructions is available on site and observed throughout the entire installation period.

iFIX is under constant development. As a result, assembly sequences may change. When installing, it is therefore essential to use the latest version of the installation instructions.

Current documents are available at  
[www.voestalpine.com/iFIX](http://www.voestalpine.com/iFIX)

Prior to installing the PV system, it must be ensured that the roof waterproofing complies with DIN standard 18531. To prevent long-term damage, the compatibility of the roof surface with iFIX must be checked. A protective mat under the iFIX sheets is not required for gravel roofs, as long as the iFIX sheets are placed on the gravel. iFIX sheets with protective mat cut-outs must be used for bituminous roof waterproofing. Should the roof cladding consist of plastic foil, iFIX sheets with aluminium-laminated protective mat blanks shall be used to prevent the roof cladding from becoming brittle. The film's compatibility with the protective mat must be approved by the film manufacturer. Fleece mats are not allowed as a carpet pad and are a hazard! Where there are localized recesses in the roof cladding that lead to puddles forming, differences in height should be compensated for by placing underlays suitable for the respective roof cladding.

If iFIX sheet metal parts are cut to size on site, ensure that their stability is not impaired and that cut edges are treated in such a way that there is no risk of injury to persons or the roof cladding from sharp corners and edges.

The assembly instructions of the PV module manufacturer must be adhered to so that the PV module is only clamped in the areas approved by the PV module manufacturer.

Avoid conductor loops when laying cables under the PV modules.

Furthermore, the following standards must be complied with:

- VDS 2023 Electrical Installations in buildings with predominantly combustible materials – Guidelines for loss prevention
- DIN 4102 Behaviour of building materials and components in case of fire
- DIN 1860 Drainage systems for buildings and land

In the event of disregard of our assembly and safety instructions and the installation or attachment of competitor components, voestalpine Automotive Components Schwäbisch Gmünd GmbH & Co. KG reserves the right to exclude liability.

## **EARTHING / EQUIPOTENTIAL BONDING**

Before commissioning, the system must be connected to the building's equipotential bonding. All components within a module row are conductively connected to each other via the interlocking of the module clamps, so that one connection per row (up to modules) is sufficient. It may be necessary to connect parts of the system to the external lightning protection, depending on the situation on the roof.

## **LIGHTNING CURRENT CARRYING CAPACITY**

As a rule, the lightning protection of a PV system or the building below it must be planned by a lightning protection specialist. In this context, the term lightning current carrying capacity is used for connections, terminals etc. that must actively discharge lightning currents as part of the lightning protection system. Each of these components must be tested and certified separately. Generally, the lightning current carrying capacity of a support system is not relevant for this problem, since the support system is not used as an arrester or air-termination rod in the context of external lightning protection. The lightning protection system should be designed completely independently of the PV system. In general, a defined separation distance must be maintained between the PV system and the lightning protection system. In particular cases, connecting the rack system to the lightning protection system is permissible, but the coupling of partial lightning currents into the electrical system must be taken into account. In these cases, it is important that the internal potential connections of the rack are connected with a low resistance and a sufficient cross-section. See separate "Notes on equipotential bonding and lightning protection".

The standards to be complied with for the design and installation of lightning protection, earthing and equipotential bonding:

Find out more about iFIX  
and visit us at  
[www.voestalpine.com/iFIX](http://www.voestalpine.com/iFIX)



DIN EN 62305	Lightning protection
DIN VDE 0185 Teil 1-4	Lightning protection (especially Part 3, Supplement 5)
DIN VDE 0100 Teil 410	Grounding
DIN VDE 0105	Operation of electrical systems
DIN VDE 0298	Electrical wiring

To ensure safe and proper installation of the system, please read through all the installation steps first. The required material is listed for each step.



## TOOL OVERVIEW

### Impact cord

About 6,0 m

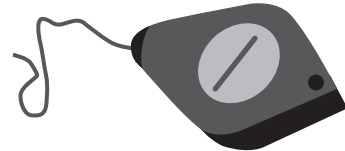

### Measuring tape

About 3,0 m



### Cordless screwdriver

Allen Bit 8 mm



### Torque wrench

Allen bit: 8 mm  
TX30 Torx bit

Adjustable from 2 to 14 Nm



### Protective gloves

EN 388 – Protection class min. 4431



### Cable ties

UV- resistant



### iFIX Spacer



## KEY COMPONENTS REQUIRED

### iFIX Base / Protect / Alu-Protect

Dimensions: 1,218 x 376 x 227 mm

Weight: 3.236 kg

Material: corrosion-protected zinc-magnesium-coated sheet steel



### iFIX S Connector Compact

Dimensions: 453 x 376 x 227 mm

Weight: 1.95 kg

Material: corrosion-protected zinc-magnesium-coated sheet steel

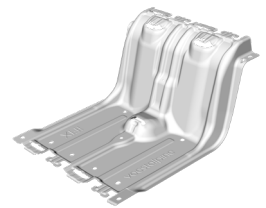

### iFIX S Deflector 1780

Wind deflector for PV module lengths up to 1780 mm

Dimensions: 2070 x 240 x 44 mm

Weight: 3.67 kg

OR

### iFIX S Deflector 2100

Wind deflector for PV module lengths up to 2100 mm

Dimensions: 2390 x 24 x 44 mm

Weight: 4.24 kg

Material: corrosion-protected, zinc-magnesium coated steel sheet

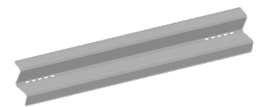
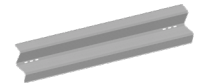

### iFIX center clamp

2 units per PV module



### iFIX end clamp

2 units per row end



### M6 grounding connector

1 unit per iFIX S Connector



## ASSEMBLY STEPS

### STEP 1

#### Laying out iFIX sheets

Alternately latch the iFIX Base to the S Connector at the markings, forming rows of metal sheets. Define the distance using the spacer. For use of the spacer, see page 16.

Material: Measuring tape, impact cord, iFIX Base, iFIX S Connector

Hint: If iFIX Base is used with iFIX Base Protect, fit the building protection mat at the same time (see page 15).



### STEP 2

#### Ballasting iFIX sheets

Once the rows have the correct spacing, weigh down the iFIX Base sheets with ballast stones, not the iFIX S Connector. Please proceed exactly according to the complaint plan from the project report.  
Note: Always place the ballast blocks starting at the high area.

Material: Ballast stones

Hint: When lightning current carrying connections are required, it is advisable to install them before PV modules are installed.



---

## STEP 3

### Install PV modules

Position the PV modules on the upper and lower positioning aids A and B, starting on the south side, and slide the upper frame to the stop C. Connect the cable and lay the PV module over the entire surface. A and B are positioning aids for the spacing of the PV modules.

Material: PV modules

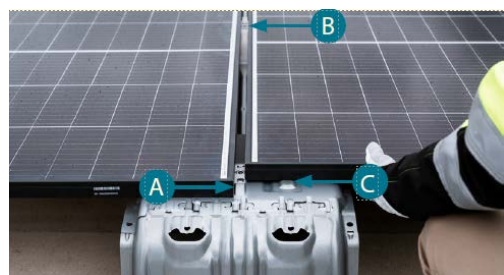

---

## STEP 4

### Cable connections

Plug the cable connections between the PV modules together and fasten them.

Material: Cable ties

Hint 1: The cables can be fixed to the C-shaped cut-outs in the sheet metal using cable ties.

Hint 2: Where supports for high snow loads (iFIX Alpin) are required, these should now be installed with the PV modules (see installation instructions for iFIX Alpin).



## STEP 5

### Set clamps

Tighten the clamps immediately after installing the PV modules with a tightening torque of 12 Nm. This involves the fine alignment of the iFIX sheet metal rows.

Material: PV modules, iFIX end clamps, iFIX centre clamps, cordless screwdriver, torque spanner with Allen bit: 8 mm

Note: Clamps must sit completely on the module frame. The gap between the vertical outer surface of the module frame and the clamp must be no more than 0.5 mm.



## STEP 6

### iFIX S Deflector

Slide one end of the iFIX S Deflector into the first upper fastening point (1), then into the lower one (2) and then into the upper one (3). Next, push the iFIX S Deflector through slightly and slide it into the three attachment points at the other end in the same order.

Insert the second iFIX S Deflector into the attachment points in the same order, overlapping the first one.

Material: iFIX S Deflector

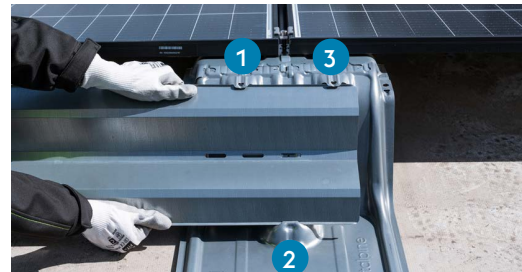
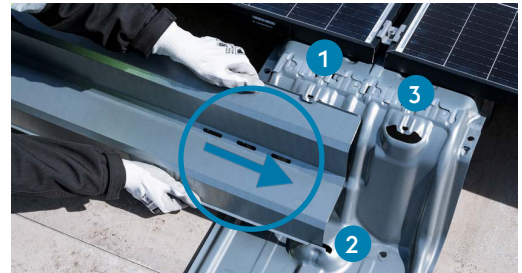

---

Move the iFIX S deflectors until they reach the end of the row, 40 to 60 mm from the edge of the iFIX S connector.

The iFIX S deflector overlap (X) results from the length of the PV modules and the selected length of the iFIX S deflector.

Hint: iFIX S Deflector 1780 for PV modules up to 1,780 mm in length. iFIX S Deflector 2100 for PV modules up to 2,100 mm in length.

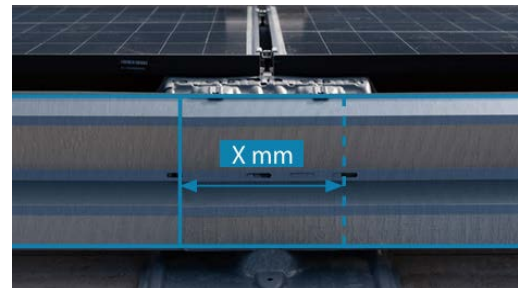
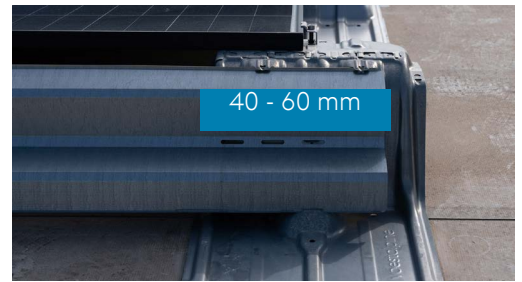

---

## STEP 7

### Potential equalisation/grounding

Tighten the M6 grounding screw through the slotted hole into the hole of the iFIX S Connector with max. 10 Nm tightening torque

Material: M6 grounding screw, cordless screwdriver, torque wrench with TX30 Torx bit

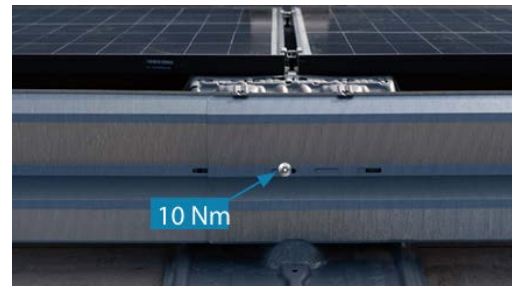

## STEP 8

### Ballasting the iFIX connector

Place the ballast on the iFIX S Connector according to the weighting plan from the project report.



## MAINTENANCE

The PV system must be checked for mechanical safety at least once a year as part of a visual and functional inspection. Particular attention must be paid to the tight fit of the PV modules - this can be done by lifting them slightly by hand. Loose modules must be secured immediately to prevent damage to the system and the roof. In addition to the direct fastening of the modules, attention must also be paid to possible thermally induced changes in the length of the system. Temperature changes can lead to the slow displacement of entire rows of modules over time.

These movements affect the mechanical stability of the system as well as the roof cladding and structural connections. For this reason, a regular check of the system offset is part of the maintenance. The required scope of maintenance depends on the degree of displacement detected and is described in detail in the chapter „I In order to maintain permanent corrosion protection, dirt should also be removed and coarse impurities removed with water. Finally, the specific specifications of the PV module manufacturer and the instructions of the installer carrying out the work, particularly with regard to the electrical components, must be observed for all maintenance work.

## GARANTIE

The “General Terms and Conditions of Warranty for iFIX” and the “General Terms and Conditions of Sale” of voestalpine Automotive Components Schwäbisch Gmünd GmbH & Co. KG, available separately and valid at the time of purchase, shall apply.

## ACCESSORIES

### iFIX Base Protect

Place a building protection mat under each iFIX Base sheet. Raise the four tabs over the sheet at the marking on the edge of the sheet.

Material: iFIX Base Protect

Hint: Take note of the orientation of the mat: A round hole in the low area of the iFIX Base plate. The mat must not cover the water drainage holes.

At the edge of the field, the construction protection mat must be pulled out to the intended notch. This prevents the connection tabs from touching the roof surface. Make sure that when pulling it out, the mat does not cover the water drainage holes of the iFIX Base.

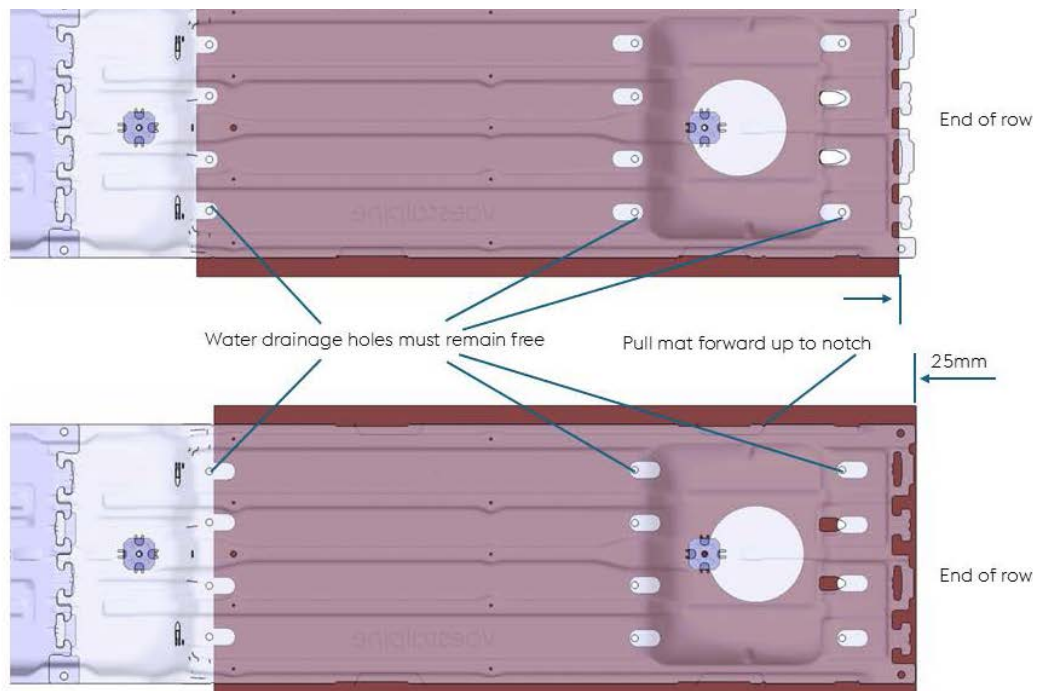
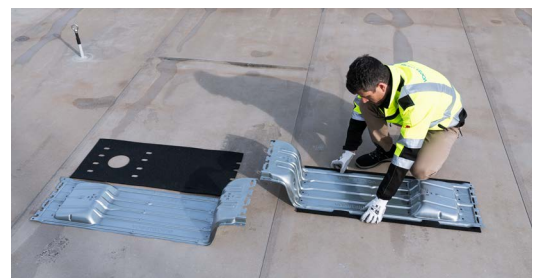
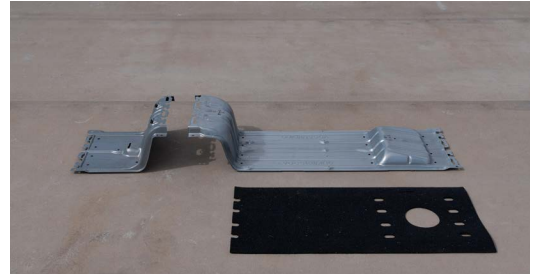

## ACCESSORIES

---

### iFIX Protector

Additional protective mat recommended for the last iFIX sheets in the assembly line

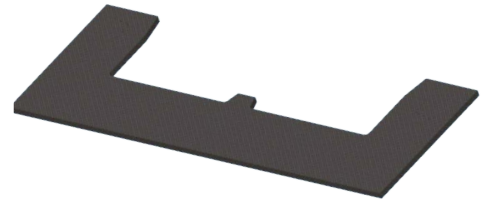

FIX Protector

### Procedure

1. Always slide the protective mat under the iFIX plate on the unconnected side of the last iFIX plate.
2. Fold the tabs of the mat upwards over the sheet metal. Ensure that the mat is positioned in the area of the sheet metal rounding and that the mat completely underlays the click area.

#### Important note

The iFIX plate has to rest on the roof in the area of the protector. The protector must not hang in the air. It is recommended to move the ballast on the iFIX plate towards the protector.

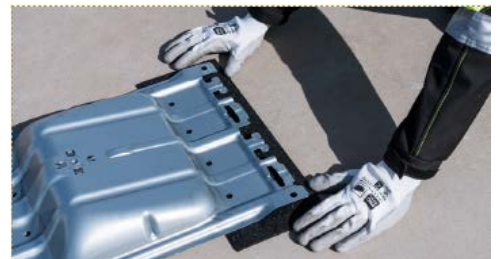

# ZUBEHÖR

## iFIX Spacer

Spacing gauge for simplified and correct alignment of the iFIX mounting plates

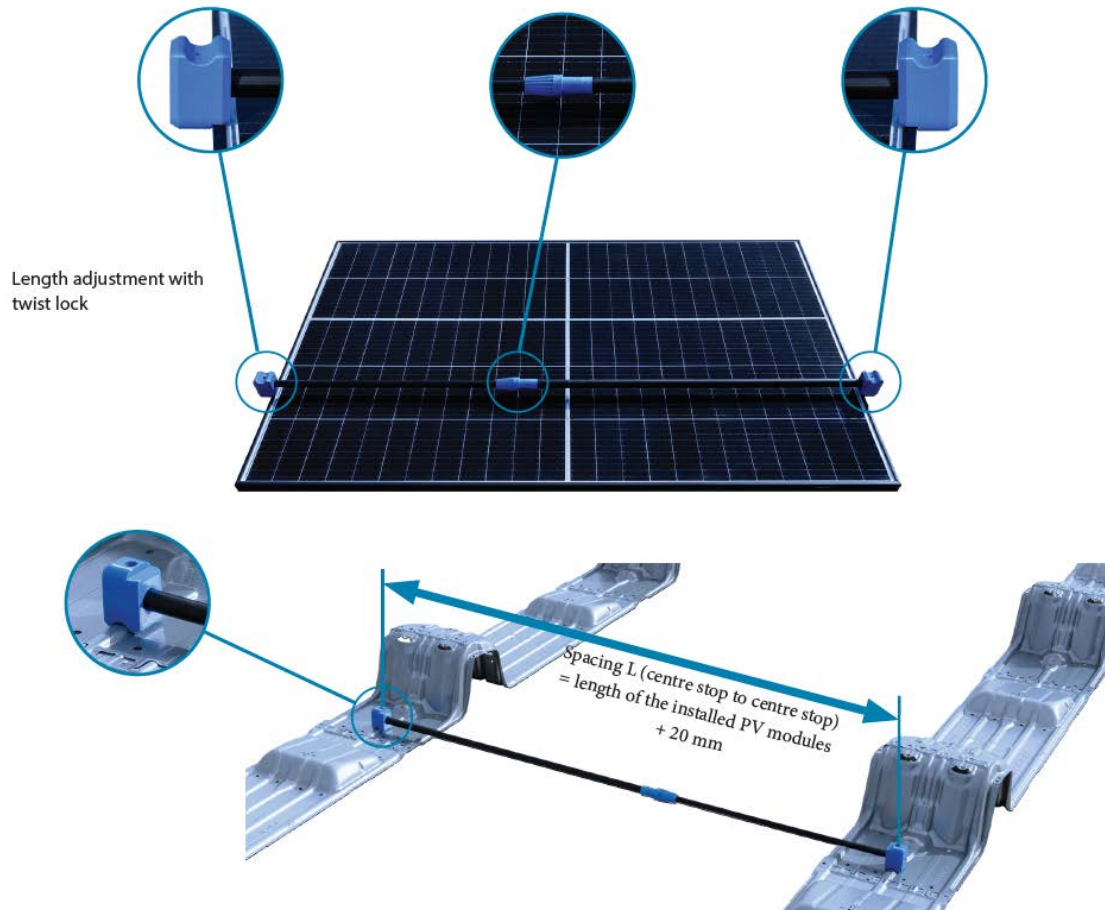

## Procedure

1. Adjust the spacer to the PV module length. Either use the stops on the blue moulded parts or follow the calculation. Release and lock the telescopic rod by turning the blue lock.
2. The two blue moulded parts of the spacer should always be positioned on the middle bead of the iFIX plate. Ensure the correct spacing at several positions on the iFIX rows.

# iFIX ONE PART - ONE CLICK



For your quick and easy source of information, click:  
[www.voestalpine.com/iFIX](http://www.voestalpine.com/iFIX)

voestalpine Automotive Components  
Schwäbisch Gmünd  
voestalpine Strasse 1  
D-73529 Schwäbisch Gmünd, Germany  
ifix@voestalpine.com  
[www.voestalpine.com/iFIX](http://www.voestalpine.com/iFIX)

voestalpine Automotive Components Schwäbisch Gmünd  
[www.voestalpine.com/iFIX](http://www.voestalpine.com/iFIX)

**voestalpine**

ONE STEP AHEAD.

# DAS UNTERNEHMEN

## Aus Kompetenz

Die voestalpine Automotive Components Schwäbisch Gmünd GmbH & Co. KG steht seit Jahrzehnten für Qualität und Service in der Umformtechnik. Als Zulieferer in der Automobilindustrie haben wir jene technische Innovationskraft entwickelt, die wir heute in die Solarindustrie investieren.

## Im Verbund

Wir schaffen neue Werte, indem wir bestehende miteinander in Verbindung bringen: vier Standorte in Deutschland und den Niederlanden.

Und vor allem: die Erfahrung von mehr als 1.500 Mitarbeiter:innen. Wenn unsere ausgewiesenen

Expert:innen für Design, Technik, Entwicklung und Produktion ihr Know-how verbinden, dann entstehen zukunftsweisende Lösungen für unsere Kund:innen.

## Mit System

Wir entwickeln Systemlösungen für die Photovoltaikbranche mit einer Bandbreite an Produkten, die perfekt aufeinander abgestimmt sind, nahtlos ineinandergreifen und an unterschiedliche Anforderungen anpassbar sind. Genau dafür steht die patentierte Systemlösung iFIX OW.



Alle Angaben entsprechen dem derzeitigen Stand unserer Erkenntnisse und Erfahrungen. Papirusdrucke können nicht aktuell gehalten werden, daher entnehmen Sie bitte die letztgültigen Inhalte der auf unserer Website befindlichen Fassung. Technische Änderungen sowie Satz- und Druckfehler vorbehalten.

Erfahren Sie mehr über iFIX OST-WEST  
und besuchen Sie uns auf  
[www.voestalpine.com/iFIX](http://www.voestalpine.com/iFIX)



Vertrieb: