

# iFIX

## One Part – One Click

The smart substructure for photovoltaic systems on flat roofs



# TABLE OF CONTENTS

**4** WHY iFIX  
ALL ADVANTAGES AT ONE GLANCE

**14** iFIX SOUTH  
TECHNICAL DATA

**6** BEST PRACTICE  
PARTNER PROJECTS

**16** iFIX TOOL  
THE SMART SOFTWARE

**8** iFIX EAST-WEST MOUNTING  
ONE PART – ONE CLICK

**18** THE COMPANY  
CERTIFICATES AND WARRANTY

**10** iFIX EAST-WEST  
TECHNICAL DATA

**20** iFIX  
PRODUCT CATALOGUE

**12** iFIX SOUTH MOUNTING  
CLICK & SLIDE



# WHY iFIX?

## ALL ADVANTAGES AT A GLANCE

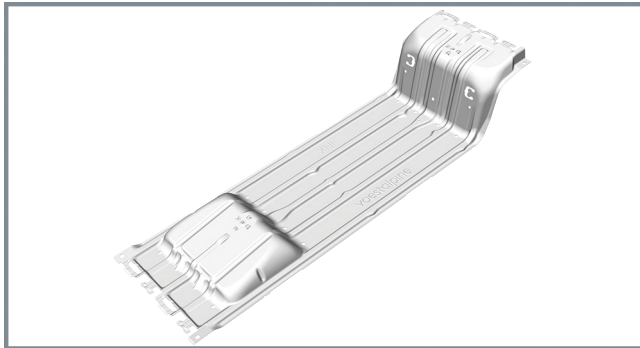

### ONE PART

One component replaces 6 to 12 individual parts of conventional systems



### ONE CLICK

Up to 50% faster assembly thanks to the smart click solution



## SMART LOGISTICS

Up to 1.8 MWp on one truck, 50 kWp on a single pallet, stackable

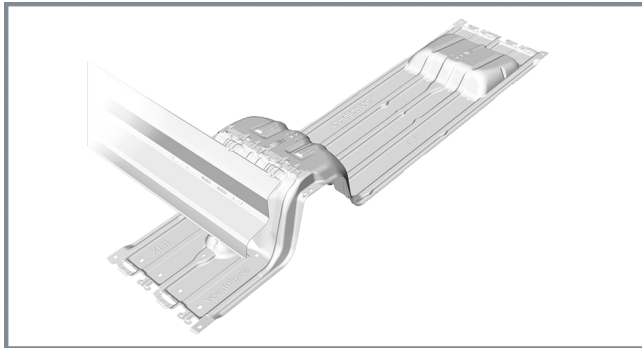

## MODULAR

Easy combination of east-west and south



## PRODUCED IN GERMANY

Manufactured in Germany using greentec steel from Austria

# BEST PRACTICE



1,6 MWp, foil roof  
GOLDBECK GmbH



4,9 MWp, foil roof  
DEE AG/Greenflash GmbH



1,12 MWp, foil roof  
Benz AluSysteme



124,67 kWp, gravel roof  
eco-tec.at Photovoltaics GmbH

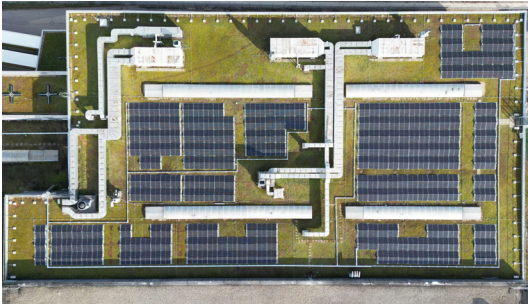

400 kWp, green roof  
Solarwerk GmbH



2,0 MWp, foil roof  
Solarwerk GmbH



98 kWp, concrete roof  
GOLDBECK GmbH



557 kWp, foil roof  
SUNKON GmbH

# iFIX EAST-WEST MOUNTING ONE PART – ONE CLICK

No need to worry about many different individual parts or time-consuming installation. iFIX is mounted in just a few steps. The component has all the fixing points needed for screw connection of the module. The additional parts required can be selected specifically depending on the photovoltaic module installed. All framed PV modules can be easily mounted on iFIX substructures.



To the mounting video  
[voestalpine.com/iFIX](https://voestalpine.com/iFIX)

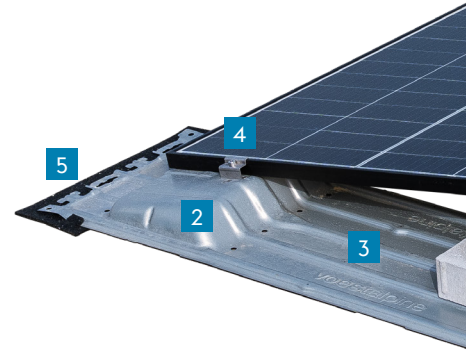

- 1 Photovoltaic module
- 2 iFIX Protect / Alu-Protect (with strips of building protection mat as standard, alternatively without)
- 3 Ballast area
- 4 End and centre clamps (specific to the photovoltaic module)
- 5 Protector

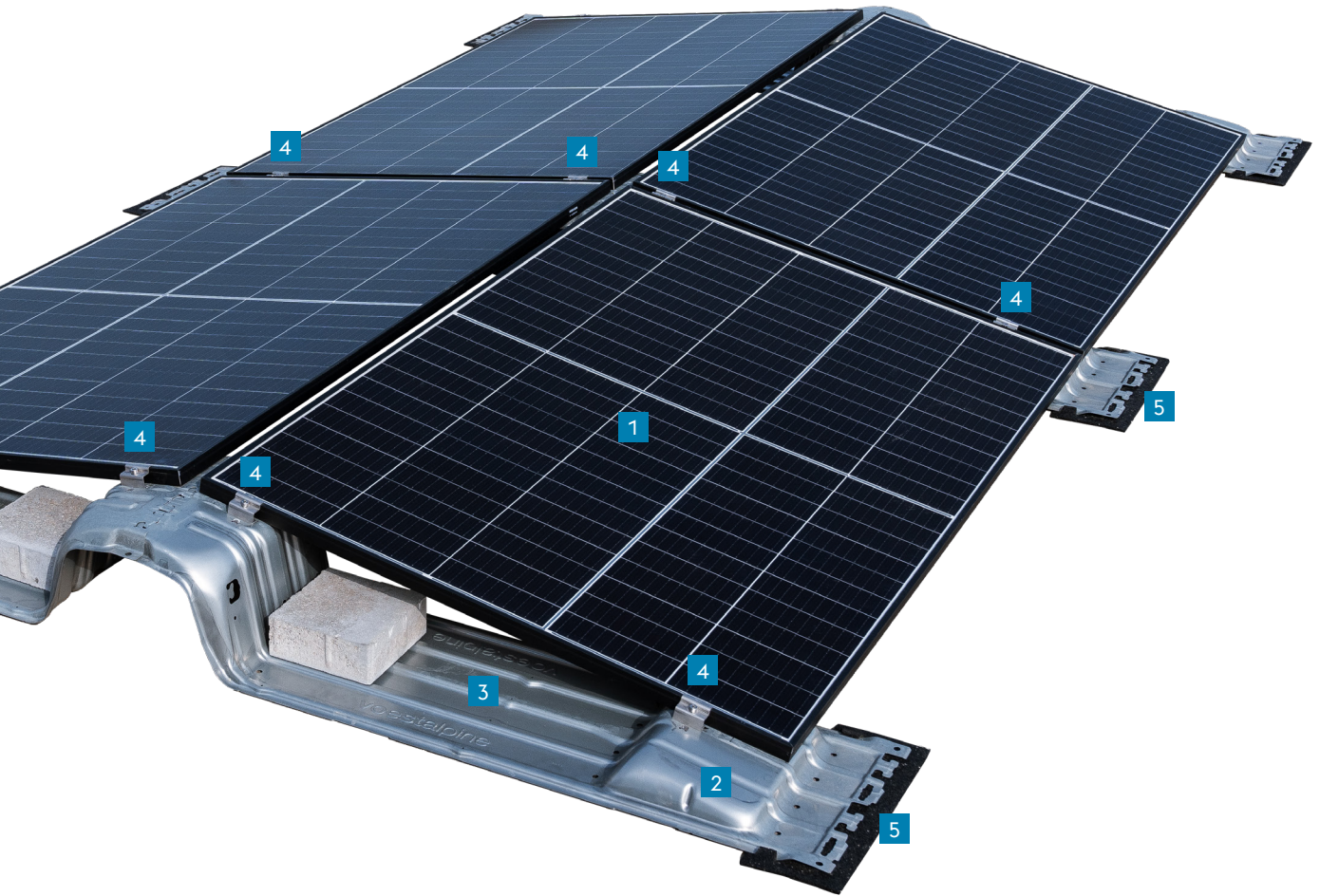

**1** INSTALL iFIX WITH ONE CLICK



**2** WEIGH DOWN WITH BALLAST



**3** MOUNT PV MODULE

Always refer to the current mounting instructions.

# iFIX EAST-WEST TECHNICAL DATA

iFIX EW is the latest iFIX product for east-west orientation to maximise yield on flat roofs throughout the day.

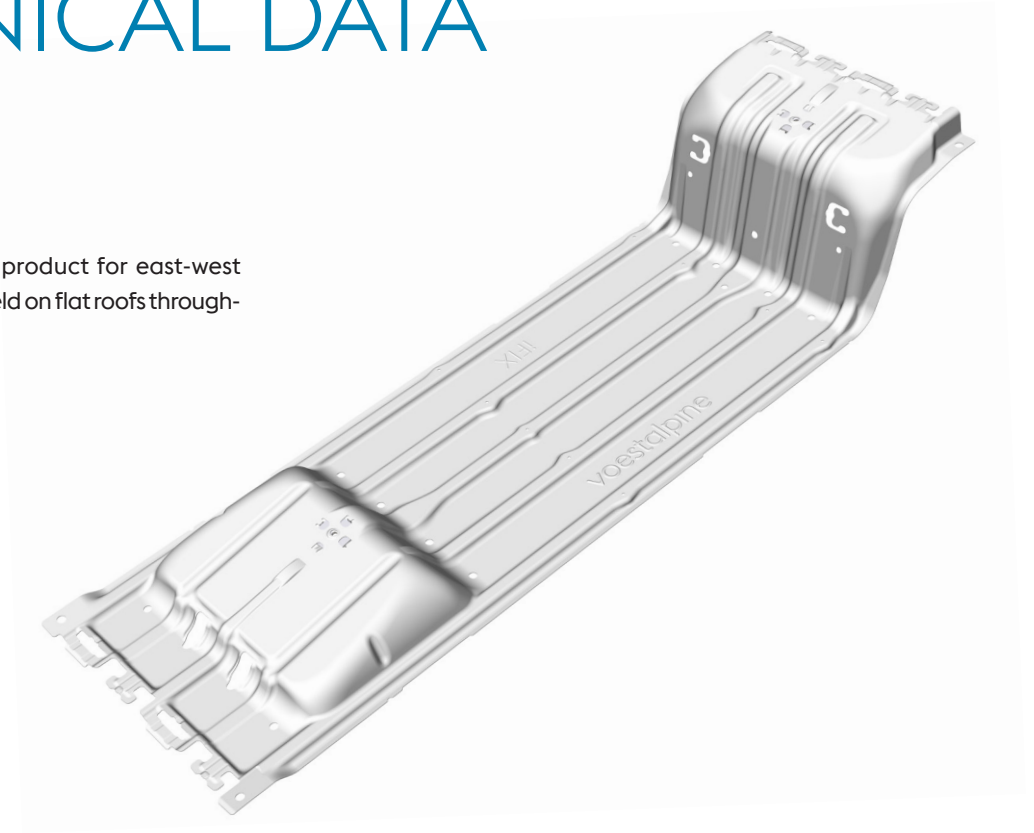

	iFIX Protect / Alu-Protect (with pre-glued strips of building protection mat)	iFIX Base with separate building protection mat
iFIX EW contact surface	0.084 m <sup>2</sup>	0.280 m <sup>2</sup>
iFIX EW weight	3,71 kg	5,04 kg
iFIX EW dimensions	1,271 x 376 x 227 mm	1,271 x 376 x 227 mm

Features	Characteristic values
Area of application	Flat roofs with max. 3° roof pitch With and without parapet Surface: Foil or bitumen covering, concrete, gravel or green roof No permanently standing water Wind zones 1 to 3, environmental conditions up to C3 Peak velocity pressure up to 1,400 N/m <sup>2</sup> * Snow load up to 3.8 kN/m <sup>2</sup> * Building height up to 50 m Minimum distance from the edge of the building 0.5 m
Surface pressure	Contact surface per mounting: max. 0.28 m <sup>2</sup> Therefore very low surface pressure
Module orientation	Horizontal
Module installation angle	10°
Mountable PV modules with a frame	Frame dimensions: Width: min. 990 mm, max. 1,145 mm Length: min. 1,650 mm, max. 2,100 mm The maximum area of 2.17 m <sup>2</sup> is the determining factor Height 30 to 40 mm
Grid dimension in the row	PV module length +20 mm Field separation after max. 15 m
Grid dimension row-to-row	1,210 mm Field separation after max. 30,0 m**
Overall height without PV module	227 mm
Material	Sheet metal: corrosion-protected zinc-magnesium-coated sheet steel Module clamps: Stainless steel
Structural engineering	Structural engineering according to Eurocode and wind tunnel reports
Authorisation	General technical authorisation/ general type approval no. Z-14.4-928

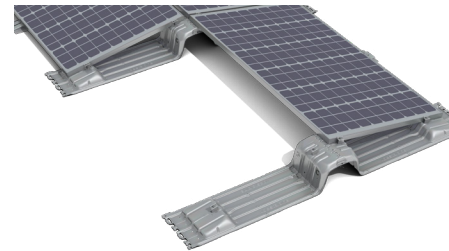
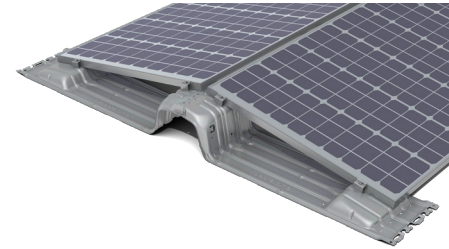

22

\* Depending on the area of the PV module

\*\* Restrictions when using lightning protection/equipotential bonding - see installation instructions for details

# iFIX SOUTH MOUNTING CLICK & SLIDE

iFIX S is the latest iFIX product for south orientation to maximise yield on flat roofs. It builds on the iFIX EAST-WEST click system. The familiar PV carrier plate from iFIX EAST-WEST is clicked into the new S Connector as usual. The iFIX Deflector is simply pushed in. It closes the north side and thus reduces the ballast.



- 1 Photovoltaic module
- 2 iFIX Protect / Alu-Protect (with strips of building protection mat as standard, alternatively without)
- 3 Ballast area
- 4 End and centre clamps (specific to the photovoltaic module)
- 5 Protector
- 6 iFIX S Connector
- 7 iFIX S Deflector



**1** INSTALL iFIX ONLY  
A FEW CLICKS



**2** WEIGH DOWN  
WITH BALLAST



**3** MOUNT PV  
MODULE



**4** INSERT  
DEFLECTOR

Always refer to the current mounting instructions.

# iFIX SOUTH TECHNICAL DATA

Only two parts are added to the familiar iFIX EW carrier plate. The iFIX S Connector and the iFIX S Deflector turn it into a south-facing system.

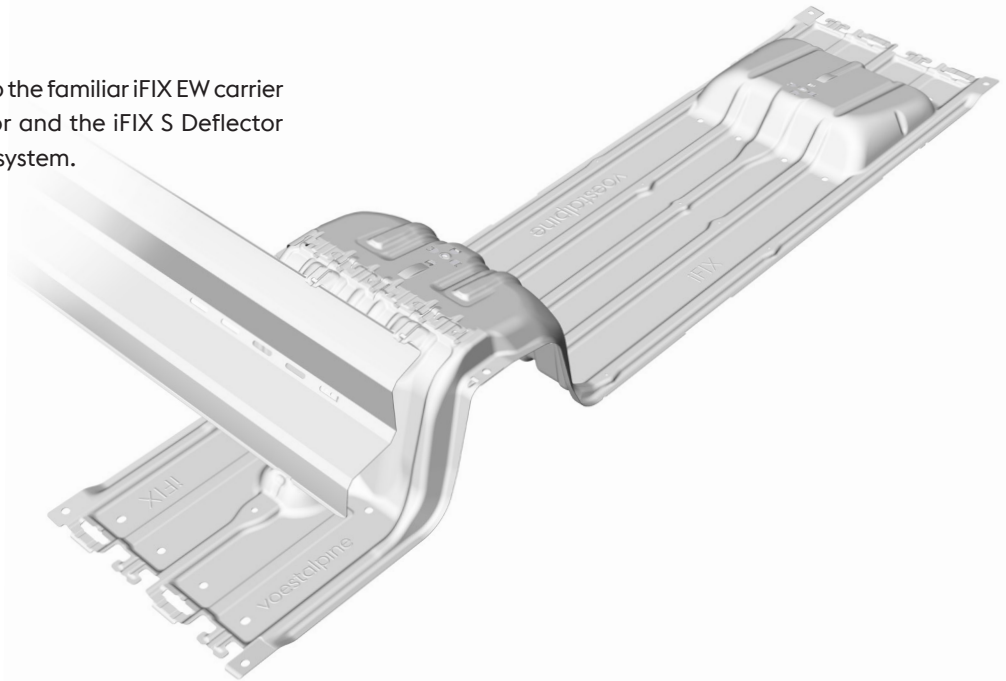

	iFIX S Connector Compact (with pre-glued aluminium-backed strips of building protection mat)	iFIX S Deflector 1780 (Wind deflector for ballast reduction)	iFIX S Deflector 2100 (Wind deflector for ballast reduction)
iFIX S contact surface	0.056 m <sup>2</sup>	2	
iFIX S weight	1.95 kg	3.67 kg	4.24 kg
iFIX S dimensions	453 x 376 x 227 mm	2,070 x 240 x 44 mm	2,390 x 240 x 44 mm

Features	Characteristic values
Area of application	Flat roofs with max. 3° roof pitch With and without parapet Surface: Foil or bitumen covering, concrete, gravel or green roof No permanently standing water Wind zones 1 to 3, environmental conditions up to C3 Peak velocity pressure up to 1,400 N/m <sup>2</sup> * Snow load up to 3.8 kN/m <sup>2</sup> * Building height up to 50 m Minimum distance from the edge of the building 0.5 m
Surface pressure	Contact surface per mounting: max. 0.316 m <sup>2</sup> Therefore very low surface pressure
Module orientation	Horizontal
Module installation angle	10°
Mountable PV modules with a frame	Frame dimensions: Width: min. 990 mm, max. 1,145 mm Length: min. 1,650 mm, max. 2,100 mm The maximum area of 2.17 m <sup>2</sup> is the determining factor Height 30 to 40 mm
Grid dimension in the row	PV module length +20 mm Field separation after max. 15 m
Grid dimension row-to-row	1,620 mm (with iFIX S Connector Compact) Field separation after max. 30,0 m**
Overall height without PV module	227 mm
Material	Sheet metal: corrosion-protected zinc-magnesium-coated sheet steel Module clamps: Stainless steel
Structural engineering	Structural engineering according to Eurocode and wind tunnel reports
Authorisation	General technical authorisation/ general type approval applied for

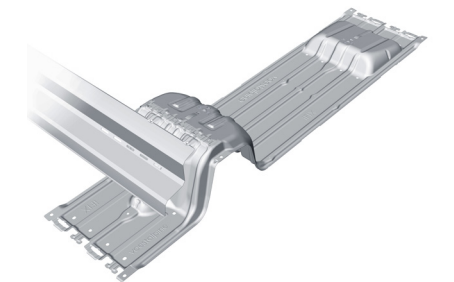
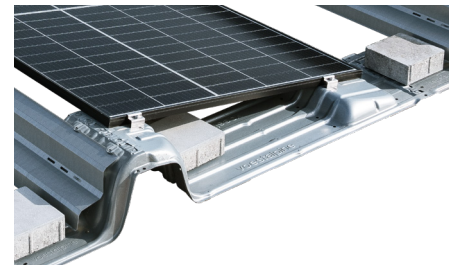

CE  
24

\* Depending on the area of the PV module

\*\* Restrictions when using lightning protection/equipotential bonding - see installation instructions for details

# iFIX TOOL

## THE SMART SOFTWARE FOR PLANNING THE iFIX MOUNTING SYSTEM

The intuitive software allows you to plan your PV project professionally in just a few simple and clear steps on your own PC or Mac. The iFIX tool is based on the well known Solar.Pro.Tool software solution from Levasoft GmbH. It supports you in planning your PV project with the iFIX mounting system for optimised module assignment and mounting system design:

- » Simple dashboard for efficient project management
- » Google and Bing Maps integration for quick and detailed recording of building dimensions
- » Versatile graphic drawing tools and export options
- » Project-specific structural engineering verification
- » Detailed results report with parts list of the required components
- » Web-based application – no need to install on your PC or Mac



# INTUITIVE ONLINE PLANNING SOFTWARE

Free iFIX Tool login  
[voestalpine.solarprotocol.com](https://voestalpine.solarprotocol.com)



# THE COMPANY



voestalpine Automotive Components Schwäbisch Gmünd GmbH & Co. KG has stood for quality and service in forming technology for decades now. We, as a supplier to the automotive industry, have achieved a high level of technical innovation, and we are now channelling our investments into the solar industry. We develop system solutions for the photovoltaic industry, including a variety of products that are perfectly coordinated, seamlessly integrated, and can be customised to meet various needs. This is precisely what the patented iFIX system solution has stood for since 2012.



ISO 9001



ISO 14001



ISO 16949



#### COMPANY FACTS

- » On the photovoltaics market since 2012
- » Production in Germany
- » Quality management system certified to ISO 9001
- » Quality management system of the automotive industry certified to IATF 16949
- » Environmental management system certified to DIN EN ISO 14001

#### PRODUCT FACTS

- » 12-year warranty period
- » 100 % greentec steel with reduced carbon footprint from Austria (made by voestalpine Steel)
- » We work according to the current state of the art and comply with the standardised regulations of the Eurocode (EN 1991-1-3, EN 1991-1-4, EN 1993-1-4, DIN 55634-1-2)
- » Testing of required load cases by an accredited testing institute
- » Expert opinion on the determination of the static design limits
- » Wind tunnel expertise to determine the positional stability
- » Internal tests accompanied by a structural engineer on the cubicle joint effect in accordance with the guideline of the BSW (the trade association of the German solar energy industry)
- » iFIX EW: Building authority approval has been granted. Lightning current carrying capacity has been verified.
- » iFIX SOUTH: Building approval and lightning current carrying capacity targeted.

Find out more about iFIX  
and visit us at  
[www.voestalpine.com/iFIX](http://www.voestalpine.com/iFIX)



# iFIX PRODUCT CATALOGUE

## iFIX substructure EAST-WEST



	iFIX Base	iFIX Protect	iFIX Alu-Protect
Description	Without pre-glued strips of building protection mat	With pre-glued strips of building protection mat, for roofs with solid insulation	With pre-glued, aluminium-backed strips of building protection mat, for roofs with solid insulation
Usage	iFIX EW and S	iFIX EW and S	iFIX EW and S
Product number	102211	102221	102222
Pcs. / packaging unit	150	150	150

## iFIX EAST-WEST building protection mats



	Base Protect	Base Alu-Protect	Protector
Description	For roofs with soft insulation 1,015 x 430 x 6 mm	Aluminium-backed, for roofs with soft insulation 1,015 x 430 x 6 mm	Aluminium-backed, for sheet metal row ends 155 x 430 x 6 mm
Usage	iFIX EW and S	iFIX EW and S	iFIX EW and S
Product number	102131	102132	102138
Pcs. / packaging unit	300	300	100

## iFIX substructure SOUTH



### iFIX S Connector Compact

Description	With pre-glued, aluminium-backed strips of building protection mat
Usage	Shading angle 22
Product number	202224
Pcs. / packaging unit	150

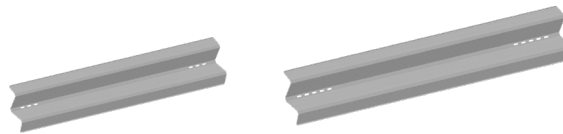

### iFIX S Deflector 1780

### iFIX S Deflector 2100

	iFIX S Deflector 1780	iFIX S Deflector 2100
Description	Wind deflector for ballast reduction	Wind deflector for ballast reduction
Usage	PV module length up to 1,780 mm	PV module length up to 2,100 mm
Product number	202205	202206
Pcs. / packaging unit	150	150

# iFIX PRODUCT CATALOGUE

## iFIX centre clamp

	iFIX centre clamp
Description	For clamping between PV modules, with screw, for frame height 30–40 mm
Usage	iFIX EW and S
Product number	102152
Pcs. / packaging unit	150



## iFIX end clamps



	iFIX end clamp 30	iFIX end clamp 32	iFIX end clamp 35	iFIX end clamp 38	iFIX end clamp 40
	For clamping PV modules at row ends, incl. screw				
Description	Width: 50 mm Height: 30 mm	Width: 50 mm Height: 32 mm	Width: 50 mm Height: 35 mm	Width: 50 mm Height: 38 mm	Width: 50 mm Height: 40 mm
Usage	iFIX EW and S	iFIX EW and S	iFIX EW and S	iFIX EW and S	iFIX EW and S
Product number	102153	102154	102155	102156	102157
Pcs. / packaging unit	150	150	150	150	150

## iFIX lightning protection / earthing



	Lightning protection connector	Lightning protection screw	Lightning protection nut	Earthing connector
Description	For connection of iFIX to the lightning conductor suitable for carrying the lightning current	Hexagonal, M10 x 12, for lightning current-carrying connections in the field	Hexagonal, M10, for lightning current-carrying connections in the field	For iFIX S Deflector
Usage	iFIX EW and S	iFIX EW and S	iFIX EW and S	iFIX S
Product number	102161	102162	102163	202213
Pcs. / packaging unit	100	200	100	100

## iFIX Alpin

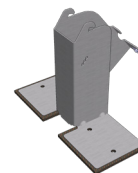

	Alpine high EW	Alpine low	T-nut M8	Alpine high S
Description	High support for high snow loads 256 x 243 x 140 mm	Low support for high snow loads 220 x 212 x 60 mm	For end clamp for fixing on the PV module frame	Optional high center support for iFIX SOUTH Advantageous for regions with high snow loads
Usage	iFIX EW	iFIX EW and S	iFIX EW and S	iFIX S
Product number	102180	102185	102188	202180
Pcs. / packaging unit	200	400	100	100

## iFIX Spacer

	iFIX Spacer
Description	Distance gauge suitable for PV modules from 1,640 to 2,100 mm in length
Usage	iFIX EW and S
Product number	102141
Pcs. / packaging unit	10



All information reflects the current state of our knowledge and experience. Paper printouts cannot be kept up to date, consequently please refer to the latest version on our website. Subject to technical changes, typesetting and printing errors.

# iFIX One Part – One Click



For your quick and easy source of information, click:  
[www.voestalpine.com/iFIX](http://www.voestalpine.com/iFIX)

voestalpine Automotive Components Schwäbisch Gmünd  
voestalpine Strasse 1  
D-73529 Schwäbisch Gmünd, Germany  
[ifix@voestalpine.com](mailto:ifix@voestalpine.com)  
[www.voestalpine.com/iFIX](http://www.voestalpine.com/iFIX)

**voestalpine**

ONE STEP AHEAD.