

LOCATIONS

USA

voestalpine High Performance Metals LLC
2505 Millennium Drive
Elgin, IL 60124
T. +1 (630) 883-3000
Email: hpm-sales.usa@voestalpine.com
www.voestalpine.com/hpm/usa

voestalpine High Performance Metals LLC
20500 Carrey Rd.
Walnut, California 91789, USA
T. + 1 (800) 368-3376
Email: hpm-sales.usa@voestalpine.com
www.voestalpine.com/hpm

CANADA

voestalpine High Performance Metals Ltd.
2595 Meadowvale Blvd.
Mississauga, ON L5N 7Y4
T. +1 (800) 665-8335
Email: sales.canada@voestalpine.com
www.voestalpine.com/hpm/canada

MÉXICO

voestalpine High Performance Metals S.A. de C.V.
Cerrada de la Noria No. 200 Int. A-14
Parque Industrial Querétaro, C.P. 76220.
Querétaro, México
T. +52 (442) 689-5900
Email: ventas.mexico@voestalpine.com
www.voestalpine.com/hpm/mexico

voestalpine High Performance Metals LLC
www.voestalpine.com/hpm/usa

voestalpine
ONE STEP AHEAD.

BÖHLER

UDDEHOLM
a voestalpine company



Producing the Highest Quality Steel
for Over 300 years

Tested and Proven by The World's Top Performers

voestalpine
ONE STEP AHEAD.

STATE-OF-THE-ART STEEL MANUFACTURING THAT PUTS YOU IN POLE POSITION

Our Cross-Rolling Technology Results in Tighter Tolerances, Smaller Oversize, and Superior Flatness.

voestalpine knife steels combine consistent high quality standards with premium machining properties. Our cross-rolling technology and state-of-the-art production facilities offer uniform material properties and minimize required machining allowances, satisfying the most stringent demands for producing and using industrial and hand knives. Local US availability and technical support are added benefits for our customers.

Your advantage by using voestalpine sheet and plate - In processing and practice compared to conventional rolled material:

- » Optimized output
- » Tighter machining allowances
- » More uniform properties
- » Less distortion in heat treatment
- » Higher safety in production

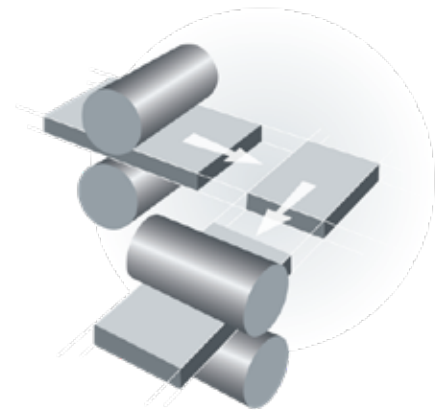

COLD WORK STEELS, HIGH SPEED STEELS, AND CORROSION RESISTANT KNIFE STEELS ARE OUR STRENGTH

Dimensional change during heat treatment

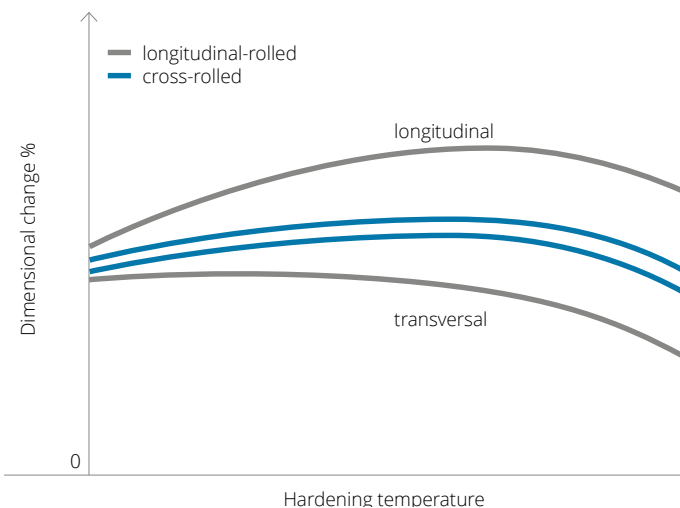

Impact energy for unnotched specimens [J] acc. SEP 1314

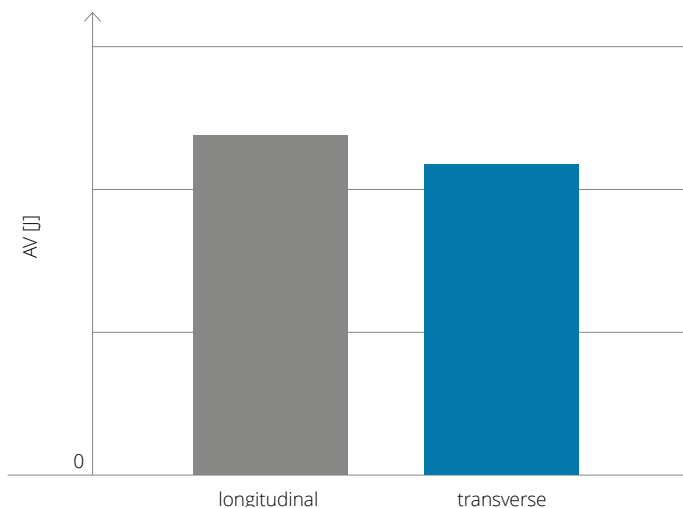

3RD GENERATION PM

Cleanliness: 3rd Generation vs. Standard PM

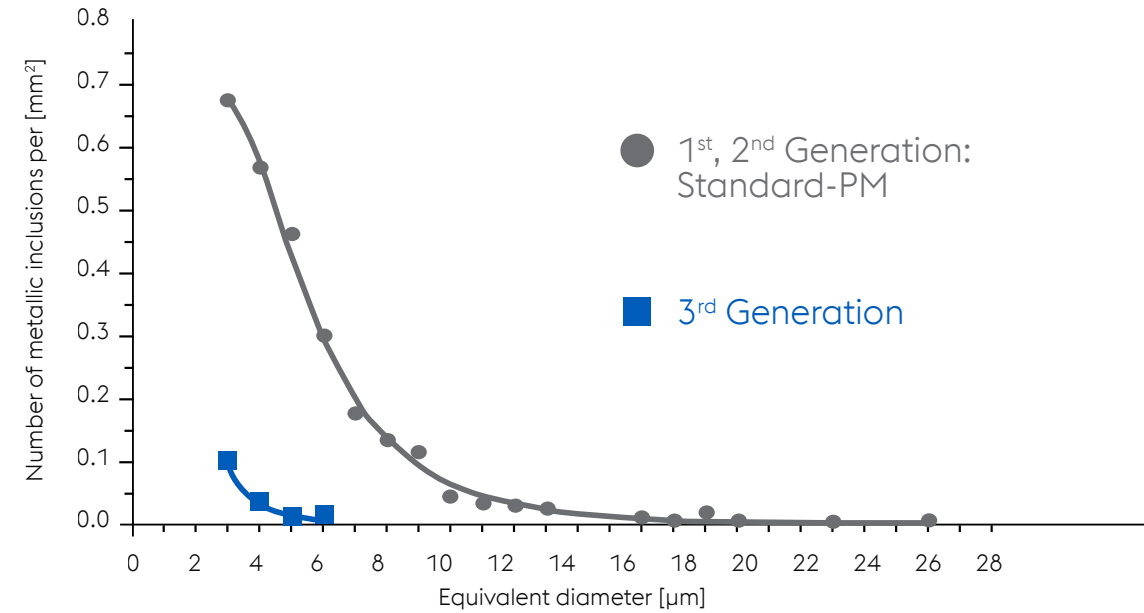

Distribution of Powder size

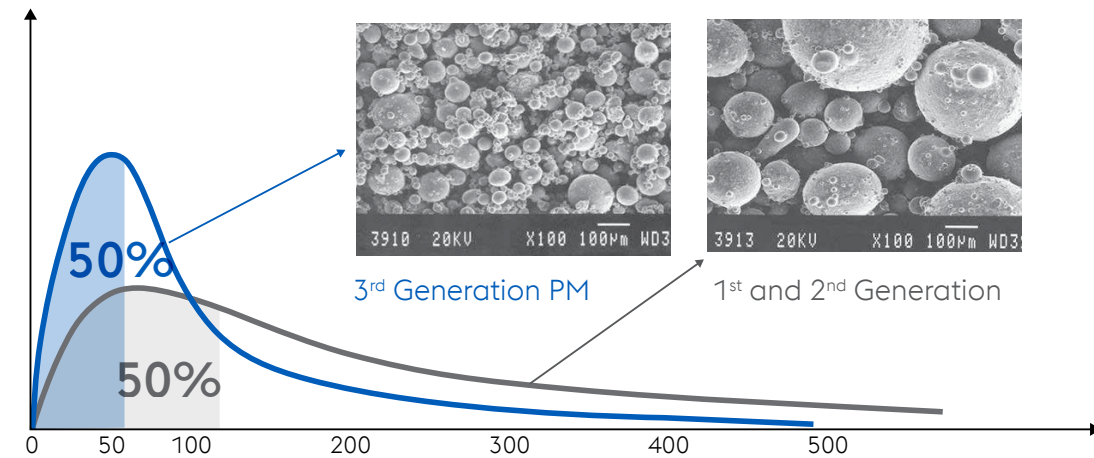

Powder Metallurgical Production

Microstructure PM materials

3rd Generation PM

FEATURES:

- » Segregation free high performance steel
- » The finest carbide distribution
- » The highest metallurgical purity
- » Isotropic properties

BENEFITS:

- » Maximum wear resistance with extremely high toughness
- » A high degree of achievable hardness
- » Very high dimensional stability
- » Very high compressive strength

HIGHLIGHT GRADES

Stainless Steels

Grade	C	Si	Mn	Cr	Mo	V	Co	W
BÖHLER M390	1.90	0.70	0.30	20.00	1.00	4.00	-	0.60
BÖHLER N690	1.08	0.40	0.40	17.30	1.10	0.10	1.50	-
Uddeholm Elmax SuperClean	1.70	0.80	0.30	18.00	1.00	3.00	-	-

Non-Stainless Steels

Grade	C	Si	Mn	Cr	Mo	V	Co	W
BÖHLER K390	2.47	0.55	0.40	4.20	3.80	9.00	1.00	2.00
BÖHLER K890	0.85	0.55	0.40	4.35	2.80	2.10	4.55	2.55
Uddeholm Vanadis 4 Extra SuperClean	1.40	0.40	0.40	4.70	3.50	3.70	-	-

Titanium and other specialty materials available for handles. Please inquire with customer service.

Stainless Steels

	AISI/DIN	Corrosion Resistance	Toughness	Edge Retention	Dimensional Stability
BÖHLER M390 MICROCLEAN	Custom PM	★★★★☆	★★★★☆	★★★★★	★★★★★
Uddeholm Elmax SuperClean	Custom PM	★★★★☆	★★★★☆	★★★★☆	★★★★★
BÖHLER N690	440C+Co/1.4528	★★★★☆	★★★☆☆	★★★★☆	★★★★☆

Non-Stainless Steels

	AISI/DIN	Compressive Strength	Toughness	Edge Retention	Dimensional Stability
BÖHLER K390 MICROCLEAN	Custom PM	★★★★★	★★★★☆	★★★★★	★★★★★
BÖHLER K890 MICROCLEAN	Custom PM	★★★★☆	★★★★★	★★★★☆	★★★★★
Uddeholm Vanadis 4 Extra SuperClean	Custom PM	★★★★☆	★★★★☆	★★★★☆	★★★★★

KEY ALLOYING ELEMENTS IN KNIFE STEELS

Carbon (C) – Carbon produces the properties that give steel its strength. As carbon increases, there is typically a corresponding increase in achievable hardness and carbide formation.

Chromium (Cr) – Chromium is responsible for carbide formation ($Cr_{23}C_6$ and Cr_7C_3) and in high amounts (around 12 wt% and above), corrosion resistance properties.

Vanadium (V) – Vanadium helps promote a finer grain structure and also forms extremely hard VC carbides. VC carbides are the hardest carbides found in steel.

Molybdenum (Mo) – Molybdenum enhances strength, hardness, toughness, and aids in corrosion resistance. It can also produce M_6C carbides.

Tungsten (W) – Tungsten increases strength and toughness. Additions of Tungsten also forms very hard WC carbides.

Cobalt (Co) – Cobalt additions increase strength and achievable hardness.

Carbide Type	Composition	Hardness (Vickers)	Hardness (HRC)
Iron	Fe_3C	1000	69
Chromium ₁	$Cr_{23}C_6$	1200	72
Molybdenum	M_6C	1400	75
Chromium ₂	Cr_7C_3	1500	76
Tungsten	WC	2600	86
Vanadium	VC	2800	87



STAINLESS GRADE DETAILS

BÖHLER M390 MICROCLEAR

Third generation powder metal technology. Developed for knife blades requiring the perfect balance of corrosion resistance with very high hardness for excellent edge retention to and molybdenum, vanadium and tungsten are added for excellent sharpness and wear resistance, can be polished to an extremely high surface finish.

Hardens and tempers to 60-62 HRC.



BÖHLER N690

Our best conventional melted grade. Great value in a corrosion resistant knife steel with excellent edge holding capabilities. Additions of chromium and vanadium enhance edge holding, while cobalt and carbon help to retain high hardness.

Hardens and tempers to 58-60 HRC



Uddeholm Elmax SuperClean

Uddeholm Elmax SuperClean is a third generation powder metallurgically produced blade steel characterized by a combination of very good wear resistance, corrosion resistance and dimensional stability.

Recommended for long production runs of smaller and complicated shapes and/or reinforced plastics.

Hardens and tempers to 60-62 HRC



STAINLES STEEL

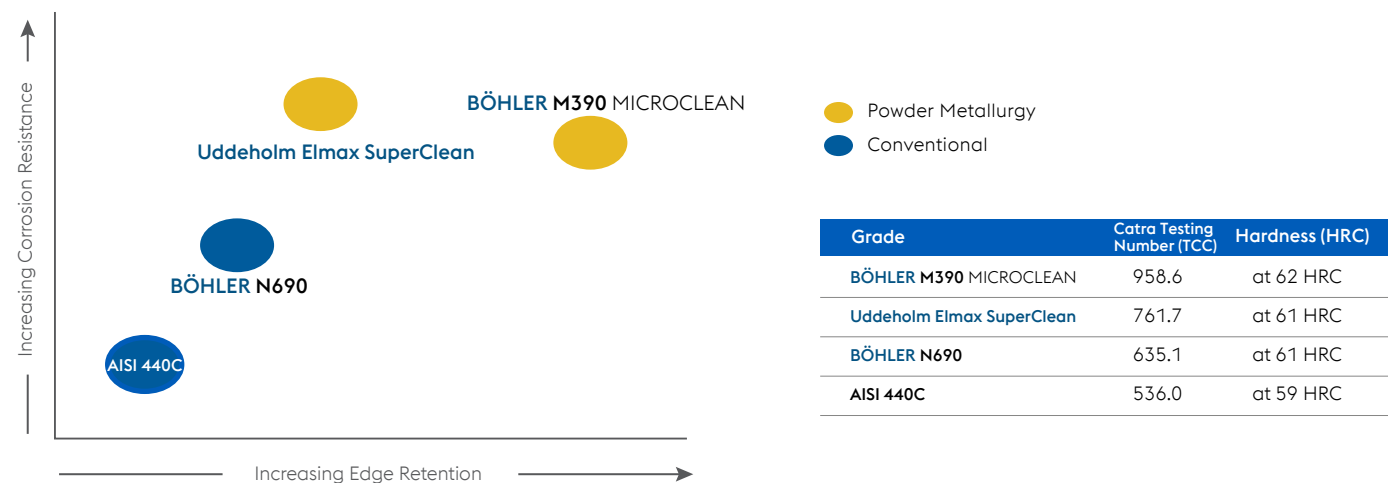

NON-STAINLESS GRADE DETAILS

BÖHLER K390 MICROCLEAR

Third generation powder metal technology and our maximum wear resistance offering for the hand knife market. Capable of reaching 64 HRC, Bohler K390 MICROCLEAR combines high amounts of Carbon and Vanadium for superior edge retention and wear resistance.



BÖHLER K890 MICROCLEAR

Third generation powder metal technology and our maximum toughness offering for the hand knife market. Bohler K890 MICROCLEAR offers the high wear resistance properties of PM tool steels while maintaining an extremely high level of toughness. Capable of reaching 64 HRC, Bohler K890 MICROCLEAR is the ideal material for large platform cutting tools.

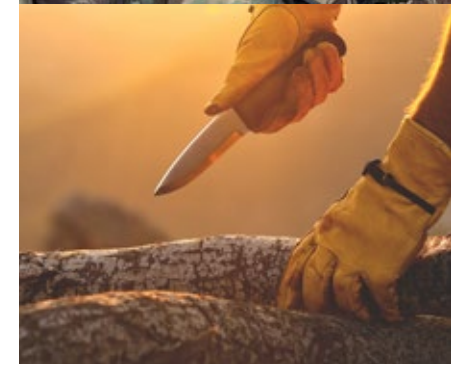

Uddeholm Vanadis 4 Extra SuperClean

Uddeholm Vanadis 4 Extra SuperClean is a highly versatile powder metallurgy (PM) tool steel known for its exceptional combination of high wear resistance, excellent ductility, and strong resistance to edge chipping. It offers outstanding machinability in both soft and hardened states, making it ideal for efficient tool production and maintenance. With high compressive strength and a reliable performance profile, it stands out as a balanced cold work PM steel.



NON-STAINLESS

