



AUTOMOTIVE SOLUTIONS

Competitive edge in lightweight design

Metal Forming Division
www.voestalpine.com/metalforming

voestalpine

ONE STEP AHEAD.

> INSIDE
INSIGHTS

MEGATRENDS IN THE AUTOMOTIVE INDUSTRY

and how we respond to them



Lightweight design

We develop innovative solutions for lightweight design based on our unique combination of material, processing and engineering expertise.

Smart mix

Matching materials and processes ensure exceptional results.

Sustainability

We consider the entire life cycle of our products, from material procurement to production and recycling.

E-mobility

E-mobility requires visionary thinking. We are your partner for revolutionary products in completely new product categories.

Tailored products

In our Competence Centers we optimize product solutions and manufacture the right products to implement your ideas and meet your requirements.

Safety

Thanks to our processing and joining expertise, we are able to ensure the best possible crash performance from any material.

Recycling

Steel can be fully recycled without any quality loss.

Anyone who want to shape mobility of the future must produce lighter and more efficient vehicles. Lightweight design is a key technology for meeting the challenges of energy and material efficiency while simultaneously increasing vehicle performance. For the automotive industry, this means that vehicles can cover longer distances on the same amount of energy.

At voestalpine, we help automobile manufacturers develop safe, distance-covering, efficient vehicles for serial production. Without lightweight design, e-mobility would be virtually inconceivable today. We are also the key partner for electric vehicle OEMs, helping them implement their concepts safely, economically and globally in all serial production sizes.

That is mobility – **one step ahead.**

TECHNOLOGY, TEAM SPIRIT AND CURIOSITY

WE SUPPORT YOU FROM PRODUCT DEVELOPMENT TO SERIAL PRODUCTION

The Metal Forming Division is one of four divisions of voestalpine. One of its key strengths is developing trendsetting solutions for the automotive industry. We have bundled the services and capabilities of over 30 locations and tailored them precisely to the requirements of automobile manufacturers and their suppliers. Its combination of material expertise and processing competence, which is unparalleled throughout the industry, and its global presence make the Metal Forming Division the preferred partner for customers who are looking for innovation and quality.

Know-how of around 12,000 employees

- » Material expertise
- » Processing competence
- » Innovation leadership
- » Geographical proximity
- » Flexibility

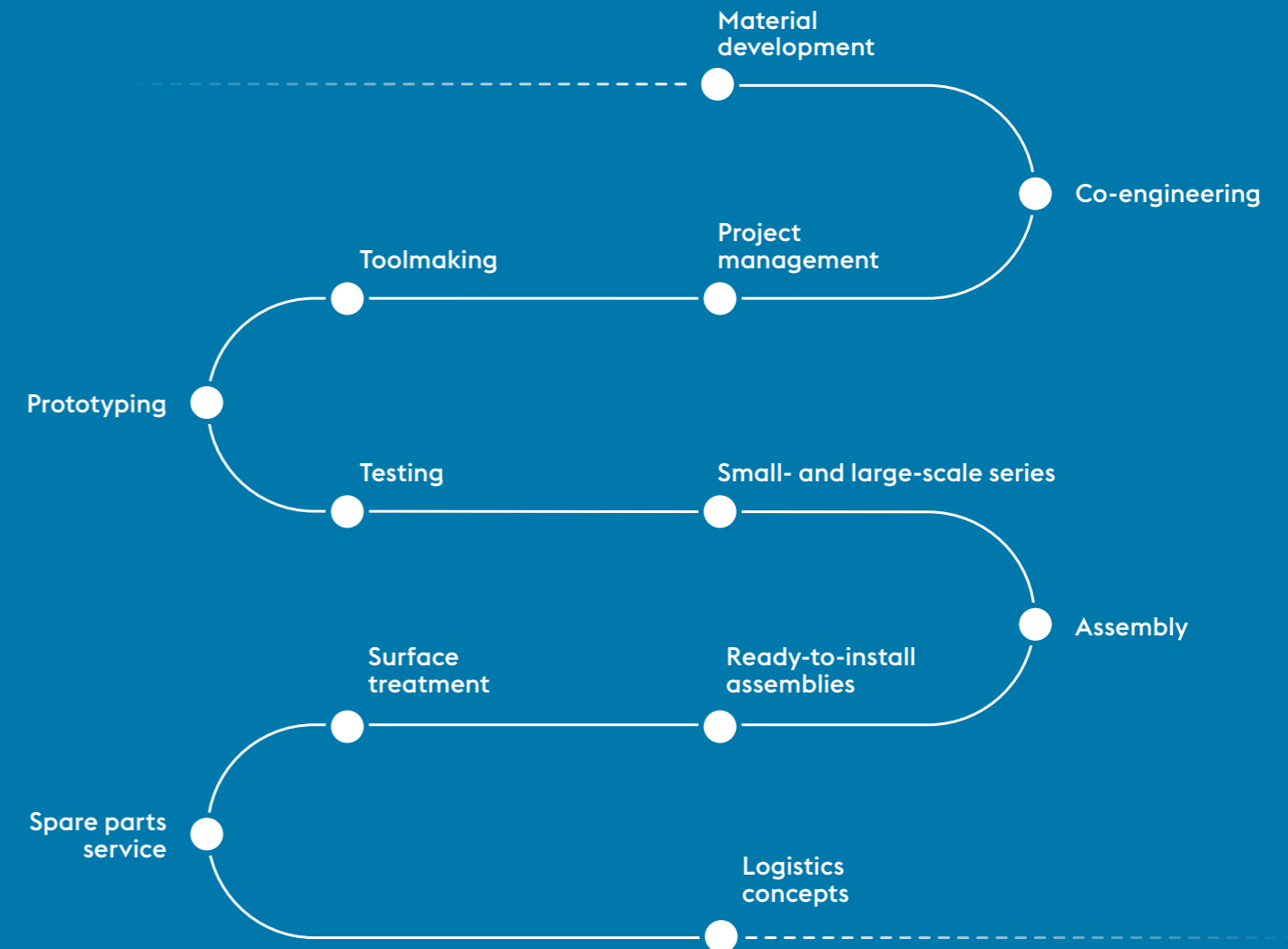
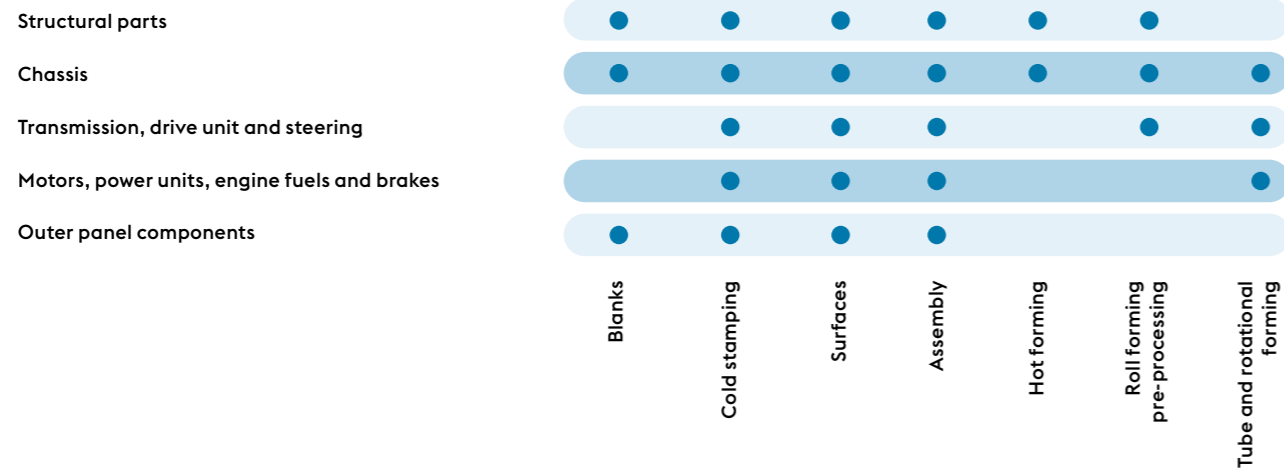

SHAPING THE FUTURE OF E-MOBILITY



Innovation requires innovation

The complex problems encountered in designing electric cars require future-oriented solutions. Find out more about our products for the next generation.

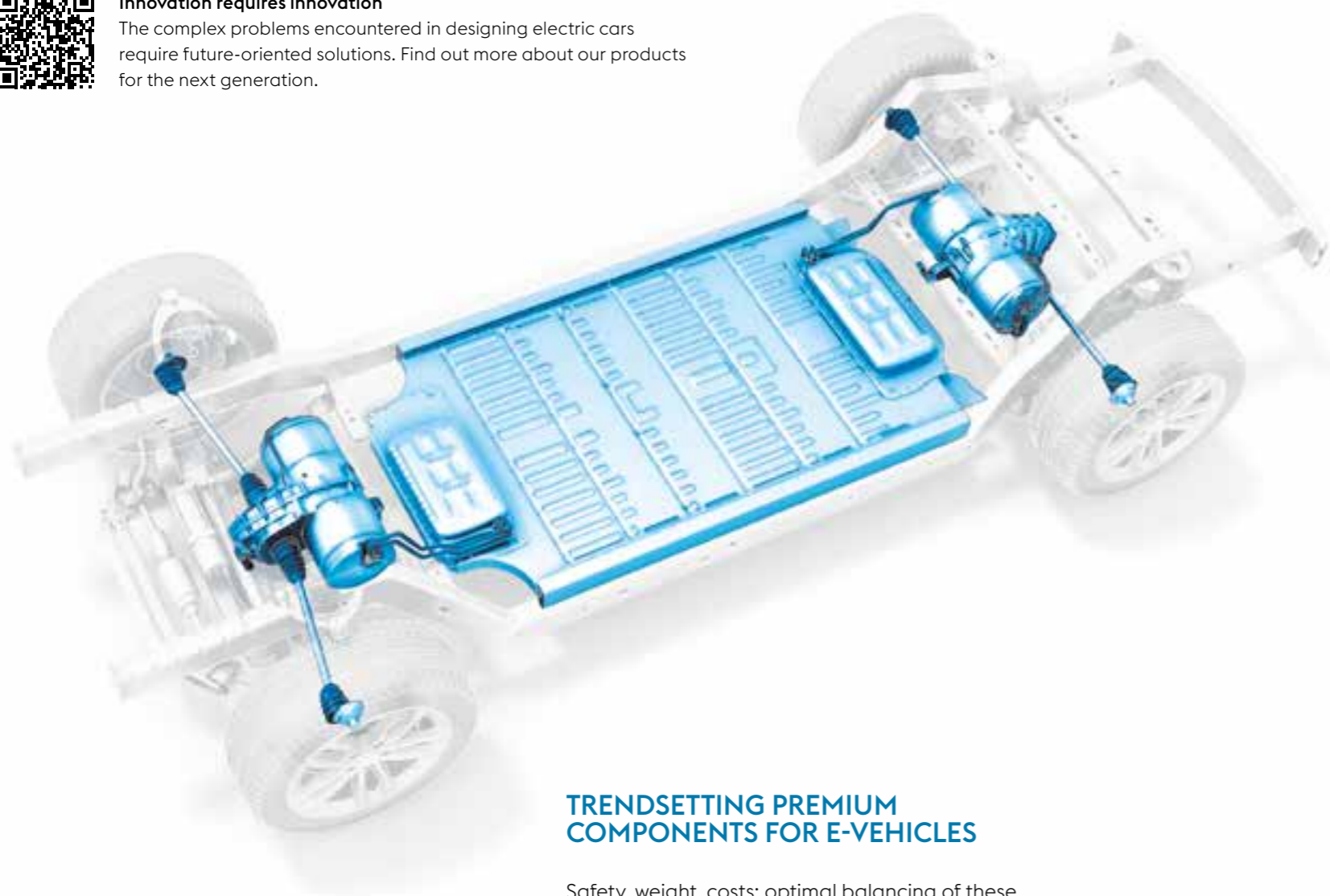

TRENDSETTING PREMIUM COMPONENTS FOR E-VEHICLES

Safety, weight, costs: optimal balancing of these three factors plays an important role in the design and development of e-vehicles. Our high-strength steels are convincing as a base material. They save weight, ensure new dimensions of safety, are more economical to manufacture than other lightweight materials and are easy to form. Our steel-aluminum hybrid components take the next step towards lightweight design and eco-balance.

BODY

Lightweight design plays a decisive role in electric vehicles to compensate for the still high weight of the battery. High-strength steel grades are basis of state-of-the-art, sustainable lightweight design. They reduce vehicle weight by 25 to 39 percent. Calculated over the life cycle of a car, they help save up to 4.5 metric tons of greenhouse gas.

BATTERY

The current sizes of batteries require new housing solutions and flexible designs. The material has to be chemically and thermally resistant and flame-retardant. It is clear that a battery box has to be securely installed to prevent leaks and dissipate excess heat in the case of an accident. When these requirements are accompanied by the need for less weight and low manufacturing costs, components made of high-strength and ultra high-strength steels or steel-aluminum hybrid solutions have great advantages over single material solutions made of aluminum, titanium or fiber composites.

flextric – battery box components

flextric components enable simple, fast and economical realization of highly secure battery boxes for car concepts of any size and in any quantity. The high-performance solution features up to 30% weight reduction, excellent crash performance and fire safety.

compacore® – lamination stacks

compacore® revolutionizes electric motors. The full-faced bonded lamination-stacks enable electric motors to be operated with lower iron losses and thus get more out of the supplied energy. This increases energy efficiency. We provide the basis with our isovac® electrical steel in combination with our innovative self-bonding varnish.

Lightweight design by voestalpine

With our extensive processing competence as a full-range supplier of hot forming, cold forming of high-strength and ultra high-strength steels, roll forming solutions and high-quality aluminum applications, we push the limits of lightweight automotive design.

SAFETY

The formula “less weight = less consumption and emissions” may never be at the expense of safety and passenger protection. To achieve these ambitious goals, voestalpine is implementing innovative design approaches combined with material expertise and crash management. The result is greater safety in the passenger compartment through better crash performance and greater fire protection for the battery.

SUSTAINABILITY

Climate protection drives e-mobility. Using materials whose life cycle assessment changes the overall balance translates into ecological advantages. Steel can be recycled without any loss of quality, putting it at the forefront in terms of life cycle assessment.



LIGHTER
CLEANER
SUSTAINABLE

SUSTAINABILITY

We consider the entire life cycle of our products

With our advanced lightweight design concepts and intelligent solutions for e-mobility, we support OEMs in all aspects of economical lightweight design, help them to realize energy savings and support them on the path to serial production of electric vehicles. We offer them material expertise and processing competence that is unique in the industry. Our international, customer-oriented production network offers optimal transport routes and the ability to quickly leverage potential for improvement through continuous learning from one another.

We take our ecological and social responsibility seriously

From pre-material consumption to sustainable supplier management and delivery to our customers – conservative use of raw and auxiliary materials and ongoing optimization of our processes and production methods assure responsible use of resources and minimize emissions.

Periodic internal audits ensure that we not only meet environmental certification requirements, but go one step further.



Details on Sustainability available at
<https://www.voestalpine.com/automotivecomponents/Sustainability>



PAVING THE WAY FOR ULTIMATE LIGHTWEIGHT DESIGN

Trendsetting solutions in every serial size

COLD STAMPING

Your specialist for cold stamping and assembly

As a specialist for cold stamping and assembly, we support you as your full-service partner: from material expertise for component design to feasibility analyses, from prototype and toolmaking services to serial production and spare parts service. With international locations in Europe, Asia, North America and Africa, we are by your side in all relevant markets.

Processing expertise

- » Pressing forces from 400 to 3,000 tons
- » Tools for dimensions up to 6,000 mm x 2,700 mm
- » State-of-the-art joining technologies for steel and aluminum
- » Forming expertise for UHSS materials up to 1,400 MPa and sheet thicknesses up to 8 mm

Competence Center

voestalpine Automotive Components
Dettingen GmbH & Co. KG/DE

HOT FORMING

Your full-range supplier for hot forming

Safer, lighter, more economical. The requirements on lightweight components are constantly increasing. As a full-range supplier, we meet these requirements with direct and indirect hot forming technologies and a focus on galvanized steels. We manufacture high-strength hot-formed parts and complex assemblies made of steel and aluminum. We set new standards with our patented phs-ultraform® and phs-directform® solutions.

phs-ultraform®

The original indirect forming process for press-hardening galvanized components.

phs-ultraform® manufactured components combine all the advantages of press-hardened steel with excellent cathodic corrosion protection for innovative lightweight design solutions. Benefit from maximum design freedom, dimensional accuracy and process reliability.

phs-directform®

The pioneer for galvanized press-hardened components produced through direct forming.

phs-directform® enables direct hot forming of hot-dip galvanized steel strip to produce highly corrosion-resistant lightweight automotive components. The cost advantages are particularly impressive for small batch sizes of less than 100,000 pieces/year and for simple component geometries.

Tailored-property parts

For optimum crash performance in automotive lightweight design.

Our strength is serial production of components with defined hardness and ductility exactly where these properties are needed. The basis is our wide range of blank configurations and hardening technologies.

Competence Center

voestalpine Automotive Components
Schwäbisch Gmünd GmbH & Co. KG/DE

A-pillar reinforcements



Engine mounts



Wheel housings



A & B pillars



Side members



Bumpers



BODY PANELS

Your specialist for large-sized pressed parts

Large structural and pressed parts for the cars of tomorrow. Our fully automatic hydraulic press lines with press forces of up to 2,800 tons allow the use of tools up to 5,000 mm and the forming of complex geometries in steel and aluminum. We also have the expertise to perform all innovative and relevant joining techniques, from roll hemming and clinching to laser welding of aluminum, in every complexity and for a wide range of quantities. Our manufacturing competence also includes high-performance dip coating and other surface treatments and solutions.

Processing expertise

- » Class A outer panel
- » Press lines with hydraulic presses up to 2,800 tons
- » Forming of highly complex geometries
- » All relevant joining techniques
- » Surface treatments
- » Press lines with up to 6 individual stages

Competence Center

voestalpine Automotive Components
Bunschoten B.V./NL

TAILORED BLANKS

Your specialist for tailored blanks

How can crash safety be increased while simultaneously minimizing vehicle weight? Our tailor-welded blanks are the best answer to these diverging requirements. With experience and expertise, we offer customized solutions for sophisticated component geometries with defined strength curves in a broad spectrum of geometries with weld seams ranging from 84 mm to 3,600 mm in length. Our production site for tailor-welded blanks in Linz is the largest of its kind in the world, allowing us to support you on a global scale.

Processing expertise

- » Tailor-welded blanks with linear, semi-linear and non-linear weld seams
- » Laser-welded aluminum blanks
- » Small-sized tailor-welded blanks
- » Tailor-welded blanks for all common hot forming processes

Competence Center

voestalpine Automotive Components
Linz GmbH/AT

Side panels



Back hatches, incl. assembly



Hoods, incl. assembly



Tailor-welded blanks



Small-sized tailor-welded blanks



Tailor-welded blanks with non-linear weld seams



TUBES AND SECTIONS

Individual roll forming solutions for demanding requirements

As a market leader, we offer cold-rolled special tubes and sections in all feasible cross-sections. The unbeatable combination of safety and economy efficiency is ideal for the demanding requirements regarding lightweight design, rigidity and crash performance. In collaboration with our customers, we are constantly looking for new innovative possibilities for the intelligent use of roll-formed sections in automobiles.

phs-rollform®

The solution for safety-relevant and crash-relevant structural parts in lightweight automotive design where high corrosion protection is required. The phs-rollform® process combines the advantages of roll forming and press hardening. This voestalpine solution results in partially hardened tubes and sections with high strength precisely where it is required. Cathodic zinc protection makes them uniquely corrosion-resistant.

Applications

- » Front, rear and lateral crash protection
- » Sills
- » Bumpers
- » Axle supports and axle structures
- » Cross members
- » Instrument panel mounts
- » Space frame structures

SPECIAL COMPONENTS

Precision tube components

We produce seamless and welded precision steel tubes, further process them and make them completely gas-tight upon request. The individual products and the corresponding manufacturing technologies are custom developed in our technology center and are also increasingly being used in the field of e-mobility. With our broad manufacturing expertise and many years of experience in the production of long length tubes up to complex profile tubes, we develop state-of-the-art shafts for electric motors together with our customers.

We specialize in bending, punching, bulging, edging, notching, riveting and combinations of various techniques in highly developed processes.

Applications

- » Airbags
- » Belt and buckle tensioners
- » Engine hood lifters
- » Pneumatic suspension: rotary pistons, external guides and pressure vessels
- » Steering components: column jackets and assemblies for steering columns
- » Hydraulic components
- » Chassis and drive components
- » Rotor shafts for the weight-saving use in electric drives
- » Air suspension: rotary pistons, external guides and pressure vessels for electric vehicles

Trunk lid tubes



Reinforcement sections for sun roofs

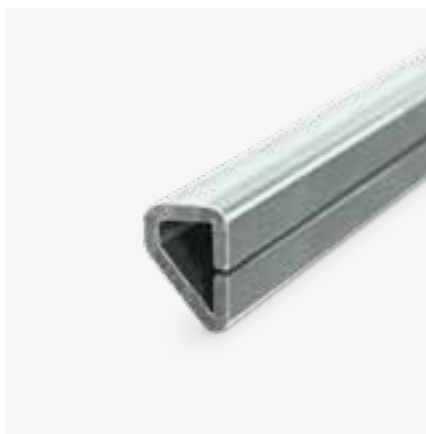

Strut braces



Pressure vessels



Airbag tube components



Steering components



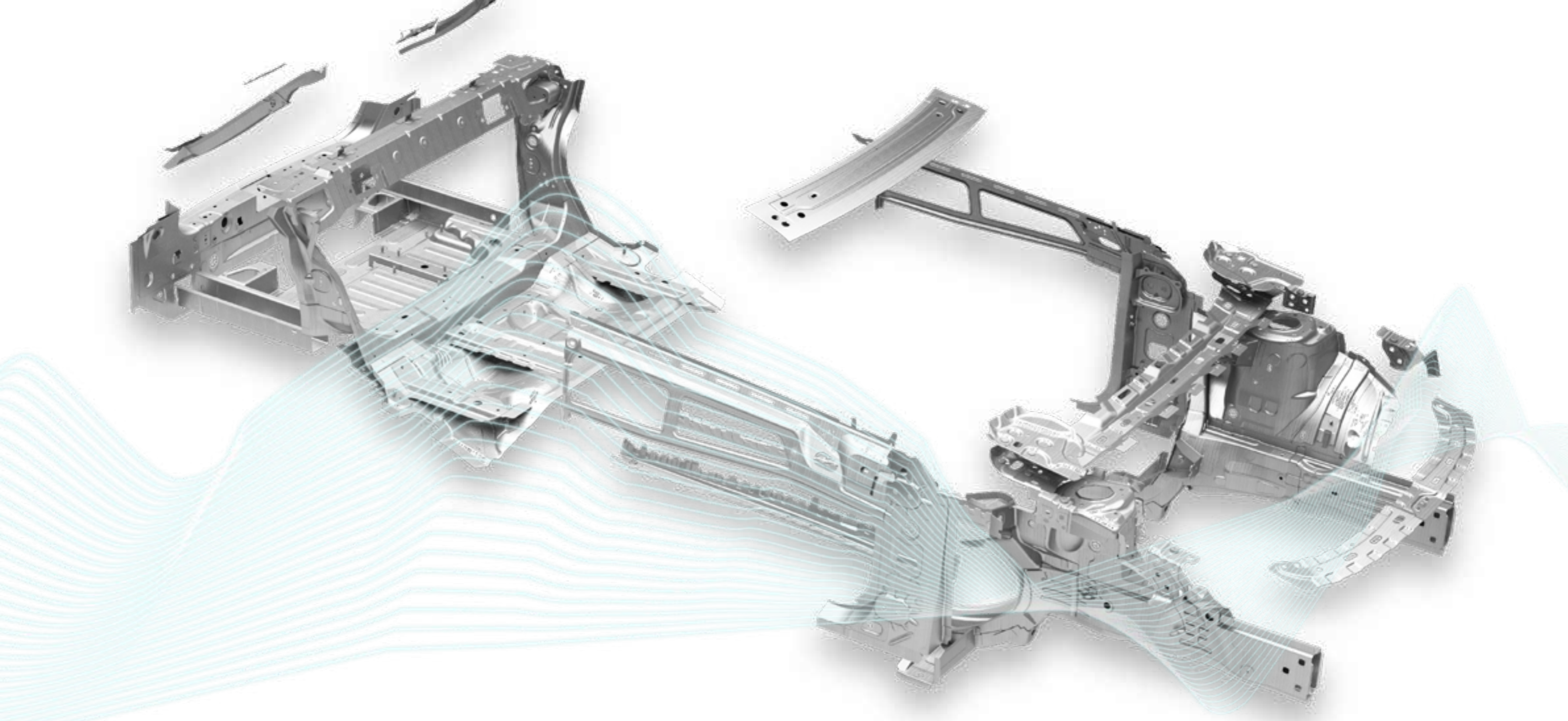

ASSEMBLIES

Ready-to-install solutions in the right place at the right time

We turn our product solutions into ready-to-install components, making an effective contribution to our customers' production efficiency. State-of-the-art equipment ensures economical, high-precision serial production of large and small batches. Efficient automation systems combined with innovative joining techniques even enable the production of complex assemblies as plug & play solutions. With surface treatments such as cathodic dip coating, we ensure the quality and service life of your parts.

» **All joining techniques**

We have the expertise to best perform all state-of-the-art joining techniques.

» **Quality all the way through to the final coating layer**

We produce the required treated and corrosion-protected surfaces on our coating and painting lines.

» **Manual assembly, partially and fully automatic assembly**

Production and assembly are based on product and quality requirements: optimal solutions especially for large assemblies.

» **Wide range of production processes**

Our competitive edge begins in part production.



SUSTAINABLE SAFETY

Unlimited availability with our life cycle spare parts service

We reliably supply spare parts throughout the entire life cycle, from the start of serial production and during full serial production up until model discontinuation. As part of our customer service, we also produce and supply parts on request over very long periods of time and even in small and very small batches. This gives automotive manufacturers and suppliers and their customers, the vehicle owners, the security and reliability they need.

[Availability over the entire life cycle](#)

[Maximum flexibility](#)

[Tailored logistics concepts](#)

GLOBAL PARTNER TO THE AUTOMOTIVE INDUSTRY

Valuable partnerships worldwide

Our customers are more than business relationships. We produce and reliably deliver our high-quality products around the world. We combine geographic proximity and flexibility with the innovativeness, expertise and reliability of the voestalpine Group. A partnership you can rely on.

We bundle the expertise in our companies at a global level and offer specialized services for the automotive industry. We deliver innovative lightweight solutions wherever they are needed.

PROXIMITY FORMS EXCELLENCE

We are where our customers are.

With around 30 locations, development centers and plants on four continents, we are a global partner who is close by. Our mutual mission is to be a single-source provider of efficient and future-oriented solutions developed in house.

Europe

voestalpine Automotive Components Birkenfeld GmbH & Co. KG
Birkenfeld/Nahe, Germany

voestalpine Automotive Components Böhmenkirch GmbH & Co. KG
Böhmenkirch, Germany

voestalpine Automotive Components Bunschoten B.V.
Bunschoten, Netherlands

voestalpine Automotive Components Dettingen GmbH & Co. KG
Dettingen/Erms, Germany

voestalpine Automotive Components Fontaine SA
Fontaine, France

voestalpine SadeF NV
Gits, Belgium

voestalpine KREMS GmbH
Krems, Austria

voestalpine Rotec Gruppe
Krieglach, Austria

voestalpine Automotive Components Linz GmbH
Linz, Austria

voestalpine Automotive Components Nagold GmbH & Co. KG
Nagold, Germany

voestalpine Automotive Components Schmölln GmbH
Schmölln, Germany

voestalpine Automotive Components Schwäbisch Gmünd GmbH & Co. KG
Schwäbisch Gmünd, Germany

USMCA

voestalpine Automotive Components Aguascalientes S. de R.L. de C.V.
Aguascalientes, Mexico

voestalpine Automotive Components Cartersville, Inc.
White, United States of America

China

voestalpine Automotive Components Shenyang Co., Ltd.
Shenyang, China

voestalpine Automotive Components Tianjin Co., Ltd.
Tianjin, China

South Africa

voestalpine Automotive Components East London (Pty) Ltd.
South Africa



- Competence Center
- Production location
- Sales location



Cold Stamping Competence Center
voestalpine Automotive Components
Dettingen GmbH & Co. KG/DE



Body Panels Competence Center
voestalpine Automotive Components
Bunschoten B.V./NL



Hot Forming Competence Center
voestalpine Automotive Components
Schwäbisch Gmünd GmbH & Co. KG/DE



Tailored Blanks Competence Center
voestalpine Automotive Components
Linz GmbH/AT



