

SAFETY BARRIERS

KREMSBARRIER 3 RH2B

**Road Restraint System suitable
for pile driving ground conditions**

EG certificate of conformity: 0006-CPR-2010

product specification Sheet C306/1



tested in accordance with EN 1317-2:

containment level: **H2**
impact severity level: **A**
working width: **W5**

tested in accordance with EN 1317-2:

containment level: **N2**
impact severity level: **A**
working width: **W3**

system test length: **14 sections or 56,00m, without driving**



08/2015

SAFETY BARRIERS

KREMSBARRIER 3 RH2B

Road Restraint System suitable
for pile driving ground conditions

product specification Sheet C306/2

for driving see C307 and C308

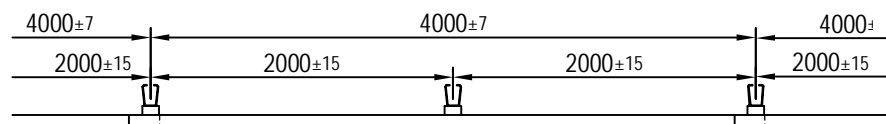
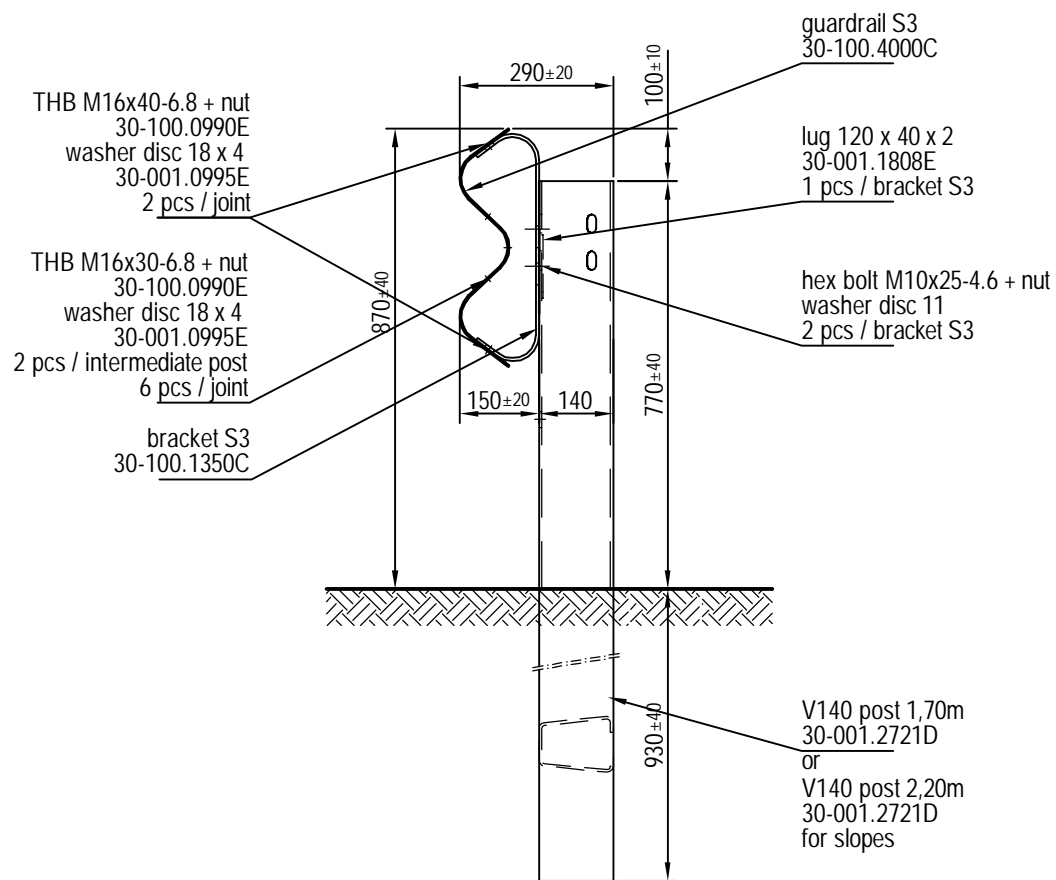

01/2015

SAFETY BARRIERS

KREMSBARRIER 3 RH2B

Road Restraint System suitable
for pile driving ground conditions

product specification Sheet C306/3

installation drawing

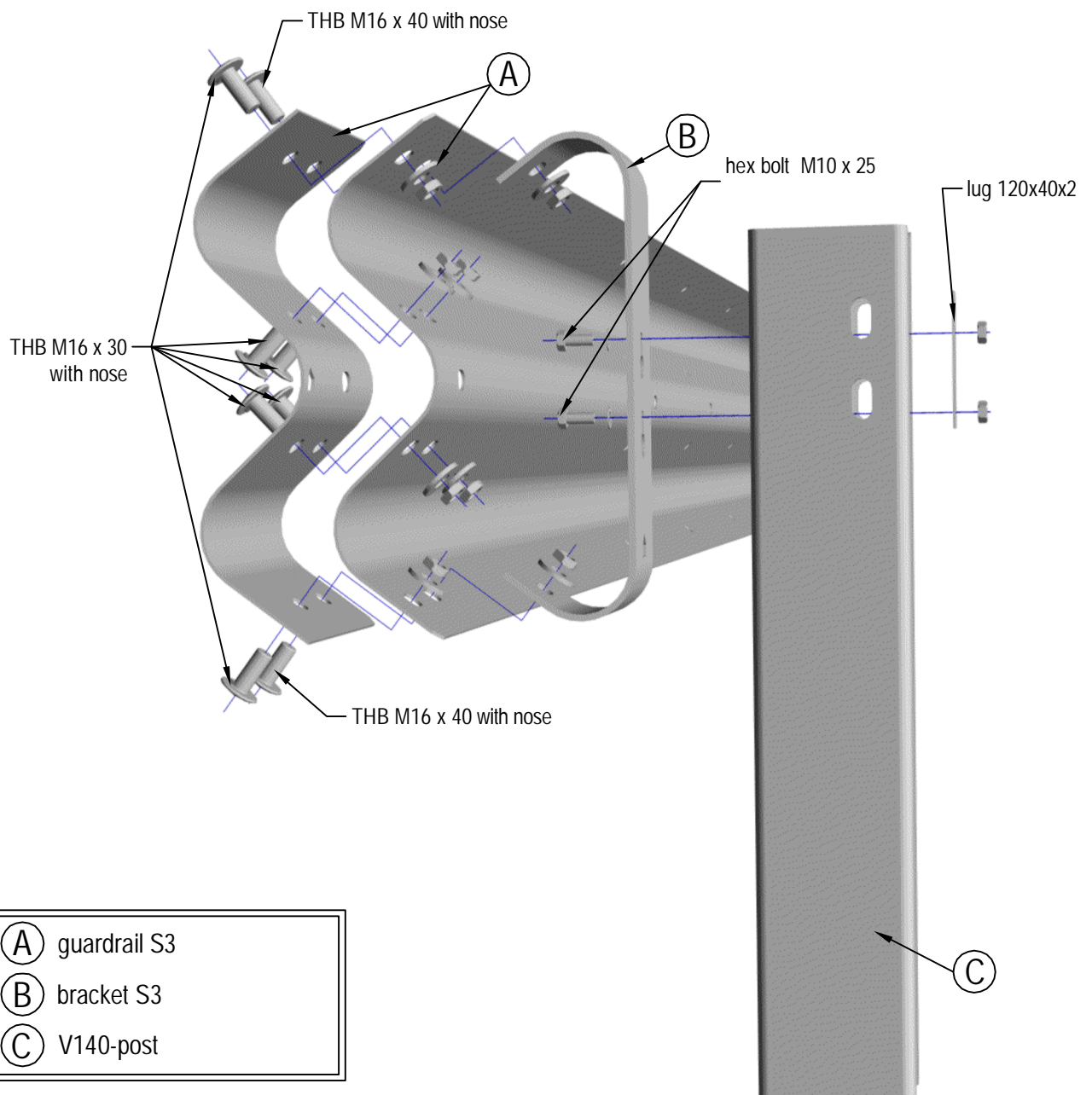

01/2015