

SAFETY BARRIERS

KREMSBARRIER 3 RH2

Road Restraint System suitable
for pile driving ground conditions

EG certificate of conformity: 0016-CPD-2010

product specification Sheet C301/1



tested in accordance with EN 1317-2:

containment level:	H2
impact severity level:	A
working width:	W5
system test length:	14 sections or 56,00m, without driving



01/2015

SAFETY BARRIERS

KREMSBARRIER 3 RH2

Road Restraint System suitable
for pile driving ground conditions

product specification Sheet C301/2

for driving see C303 and C304

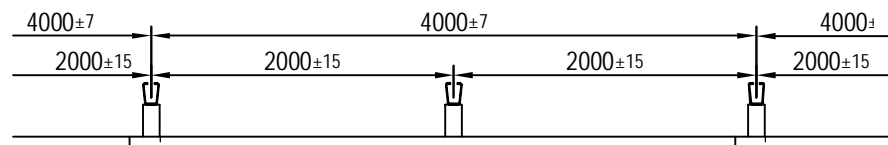
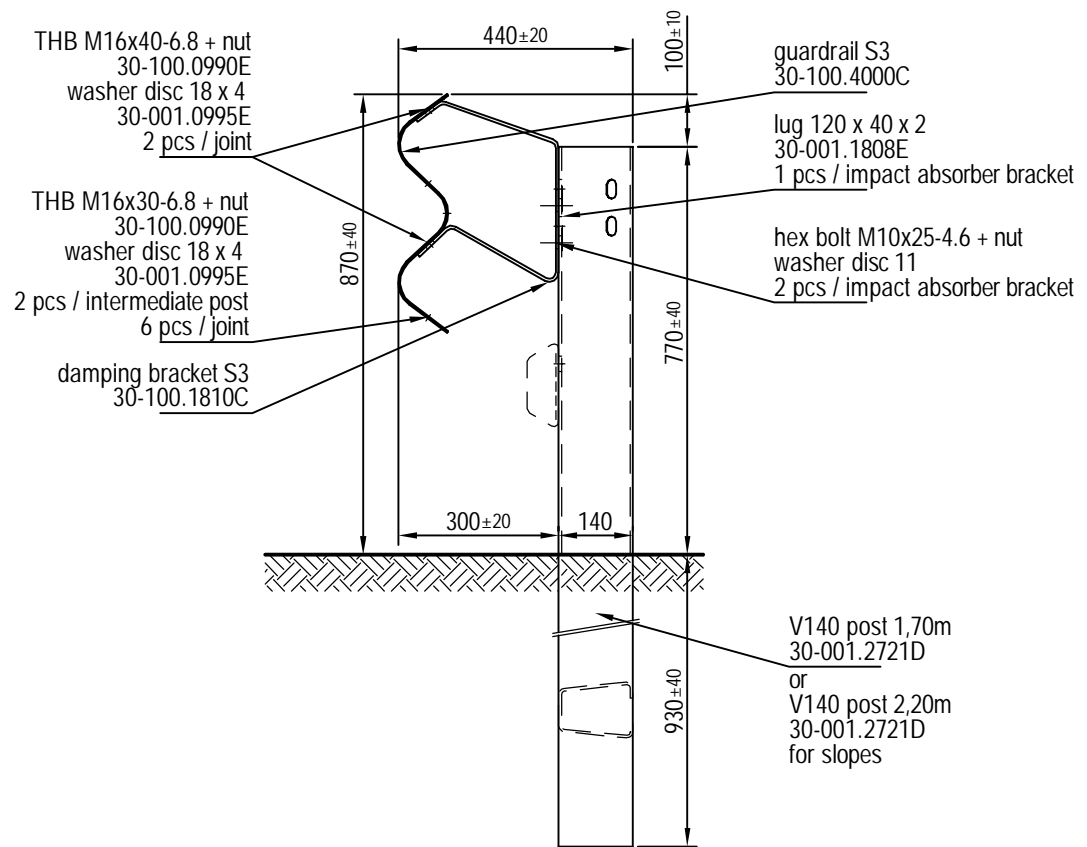

01/2015

SAFETY BARRIERS

KREMSBARRIER 3 RH2

Road Restraint System suitable
for pile driving ground conditions

product specification Sheet C301/3

installation drawing

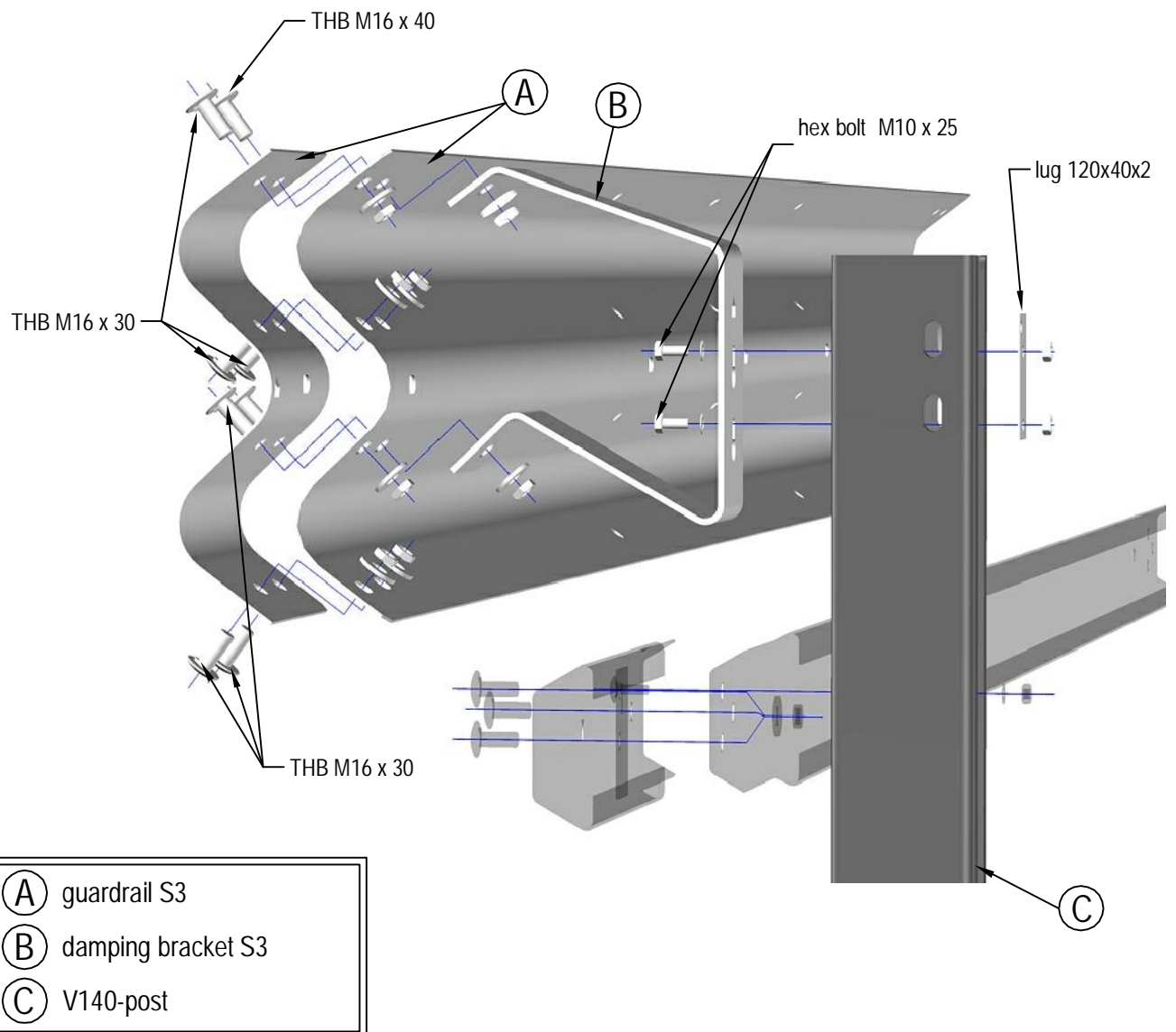

01/2015