

SAFETY BARRIERS

KREMSBARRIER 1 RH2 MÜF

Extendable restraint system for central medians

product specification sheet C109/1

EG certificate of conformity: 0142-CPD-2010



tested in accordance with EN 1317-2:

containment level:	H2
impact severity level:	B
working width:	W5
system test length:	15 sections or 57,00m, without driving

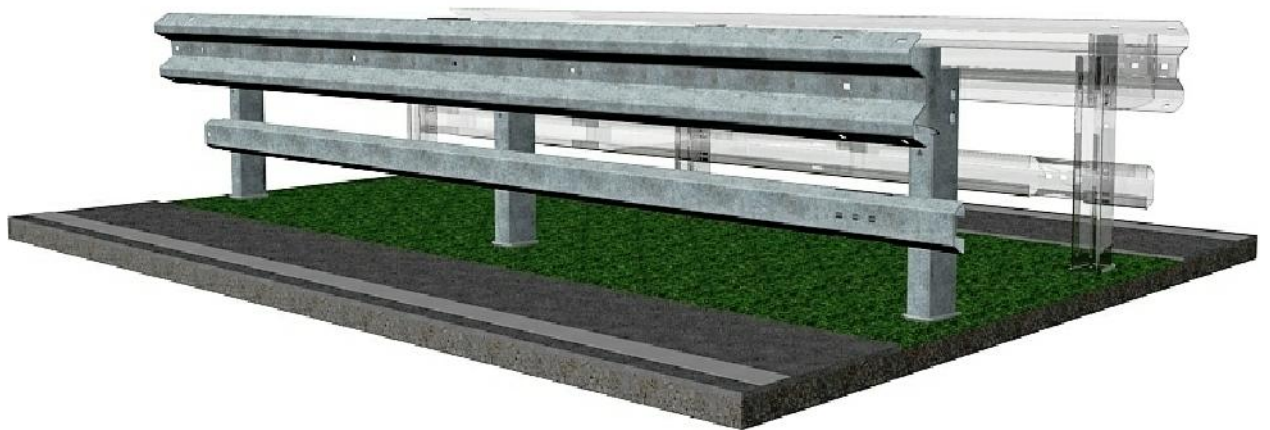

01/2015

SAFETY BARRIERS

KREMSBARRIER 1 RH2 MÜF

Extendable restraint system for central medians

product specification sheet C109/2

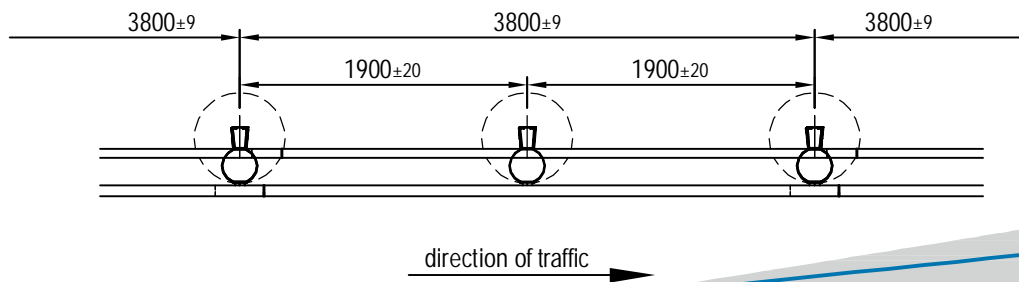
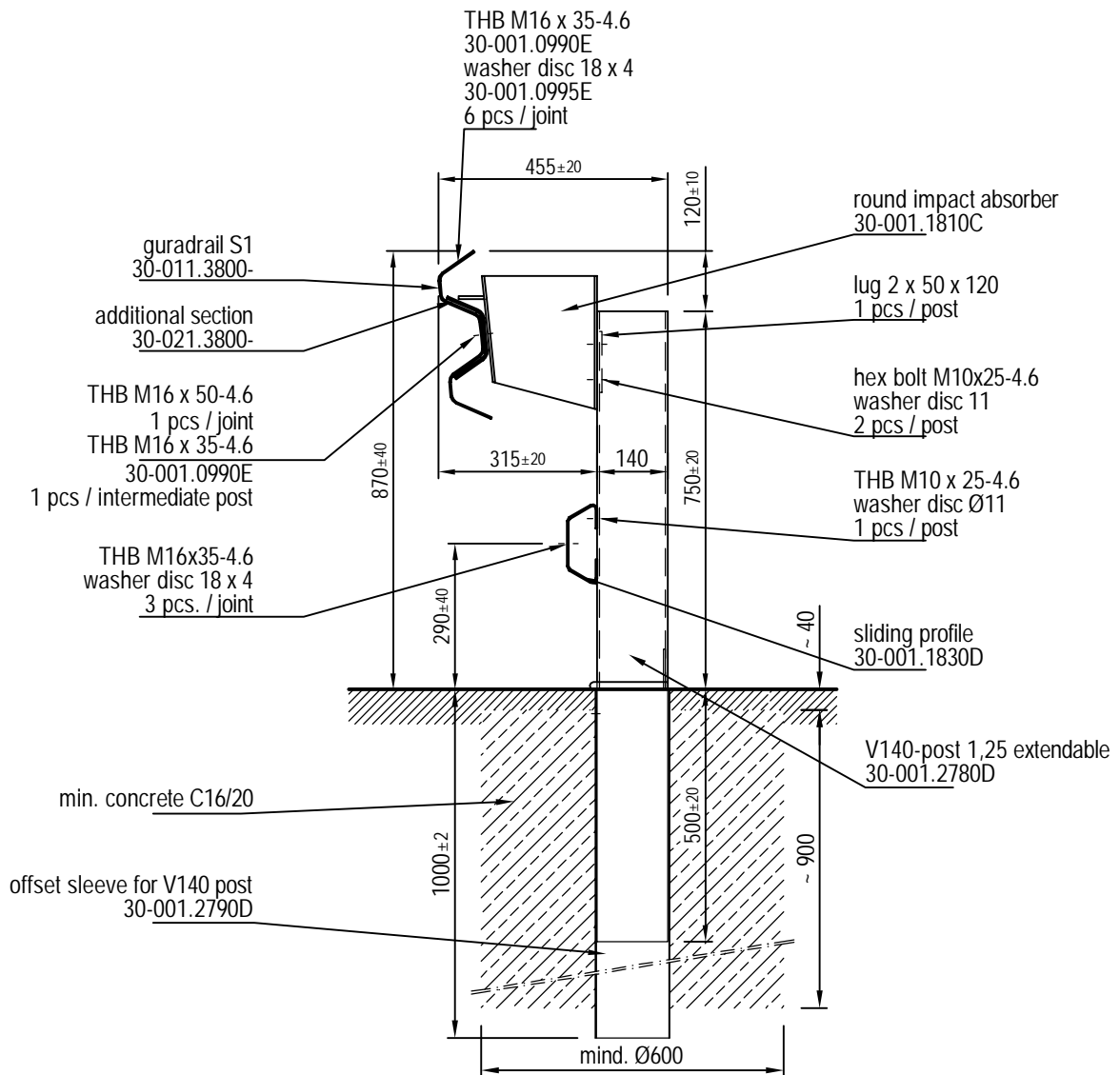

01/2015

SAFETY BARRIERS

KREMSBARRIER 1 RH2 MÜF

Extendable restraint system for central medians

product specification sheet C109/3

installation drawing

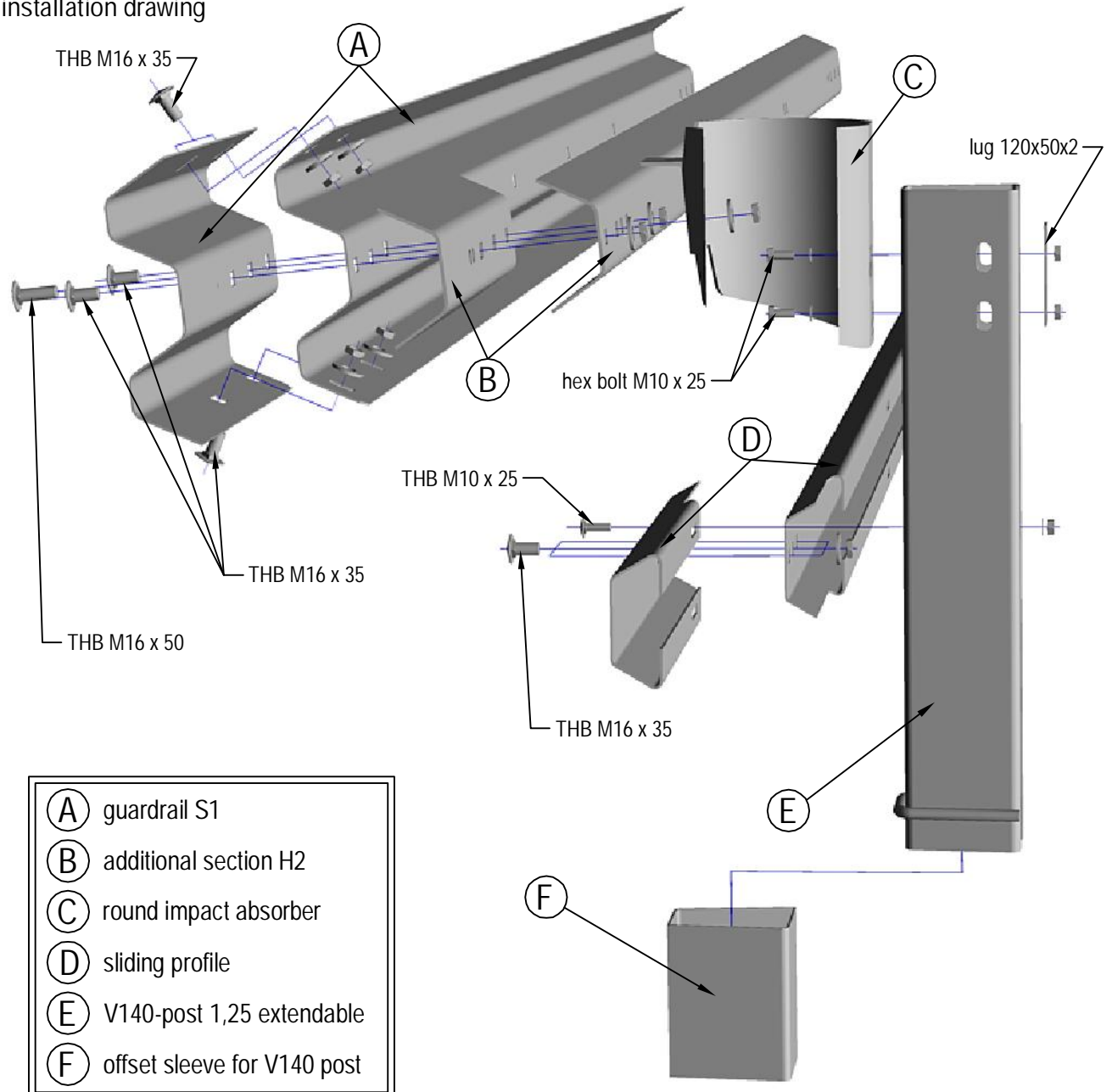

- Ⓐ guardrail S1
- Ⓑ additional section H2
- Ⓒ round impact absorber
- Ⓓ sliding profile
- Ⓔ V140-post 1,25 extendable
- Ⓕ offset sleeve for V140 post

01/2015