

SAFETY BARRIERS

KREMSBARRIER 3 RH2

Road Restraint System with lower
guardrail on civil structures

EG certificate of conformity: 0005-CPD-2010

product specification sheet C302/1



tested in accordance with EN 1317-2:

containment level:	H2
impact severity level:	B
working width:	W5
system test length:	14 sections or 56,00m, without driving



01/2015

SAFETY BARRIERS

KREMSBARRIER 3 RH2

Road Restraint System with lower guardrail on civil structures

product specification sheet C302/2

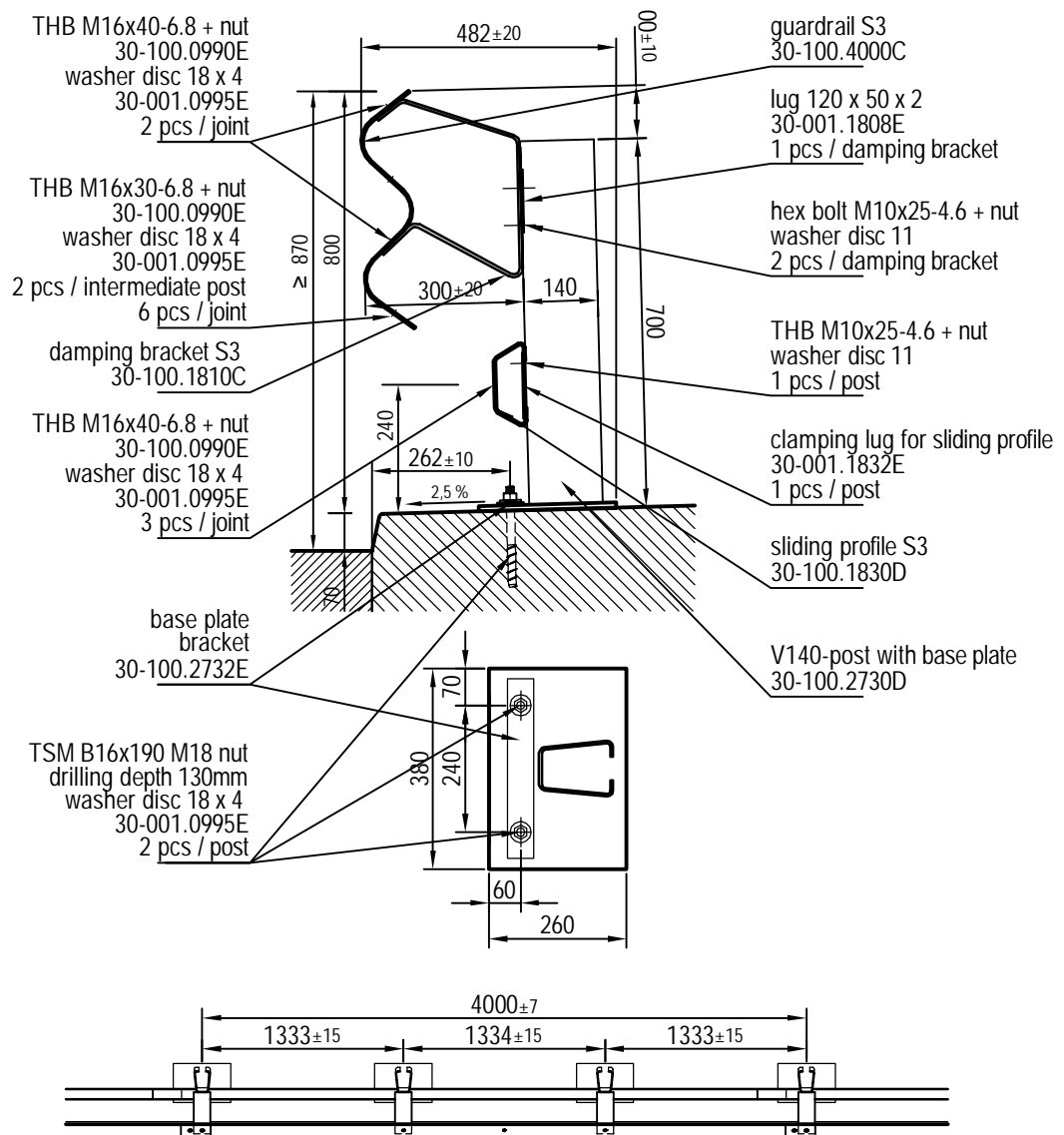

01/2015

SAFETY BARRIERS

KREMSBARRIER 3 RH2

Road Restraint System with lower guardrail on civil structures

product specification sheet C302/3

installation drawing

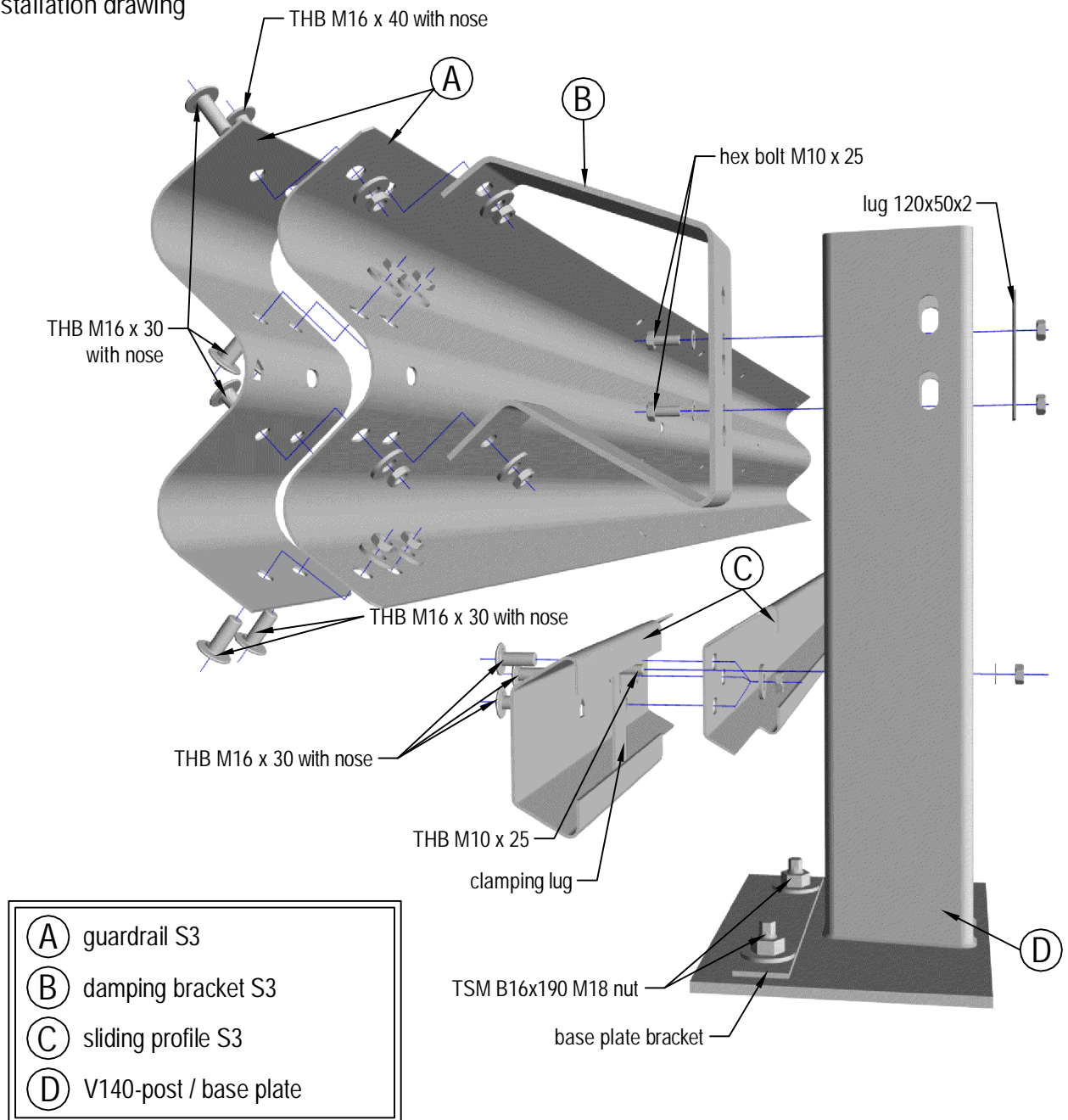

01/2015

SAFETY BARRIERS

KREMSBARRIER 3 RH2

Road Restraint System with lower guardrail on civil structures

product specification sheet C302/5

dilatation +/-100

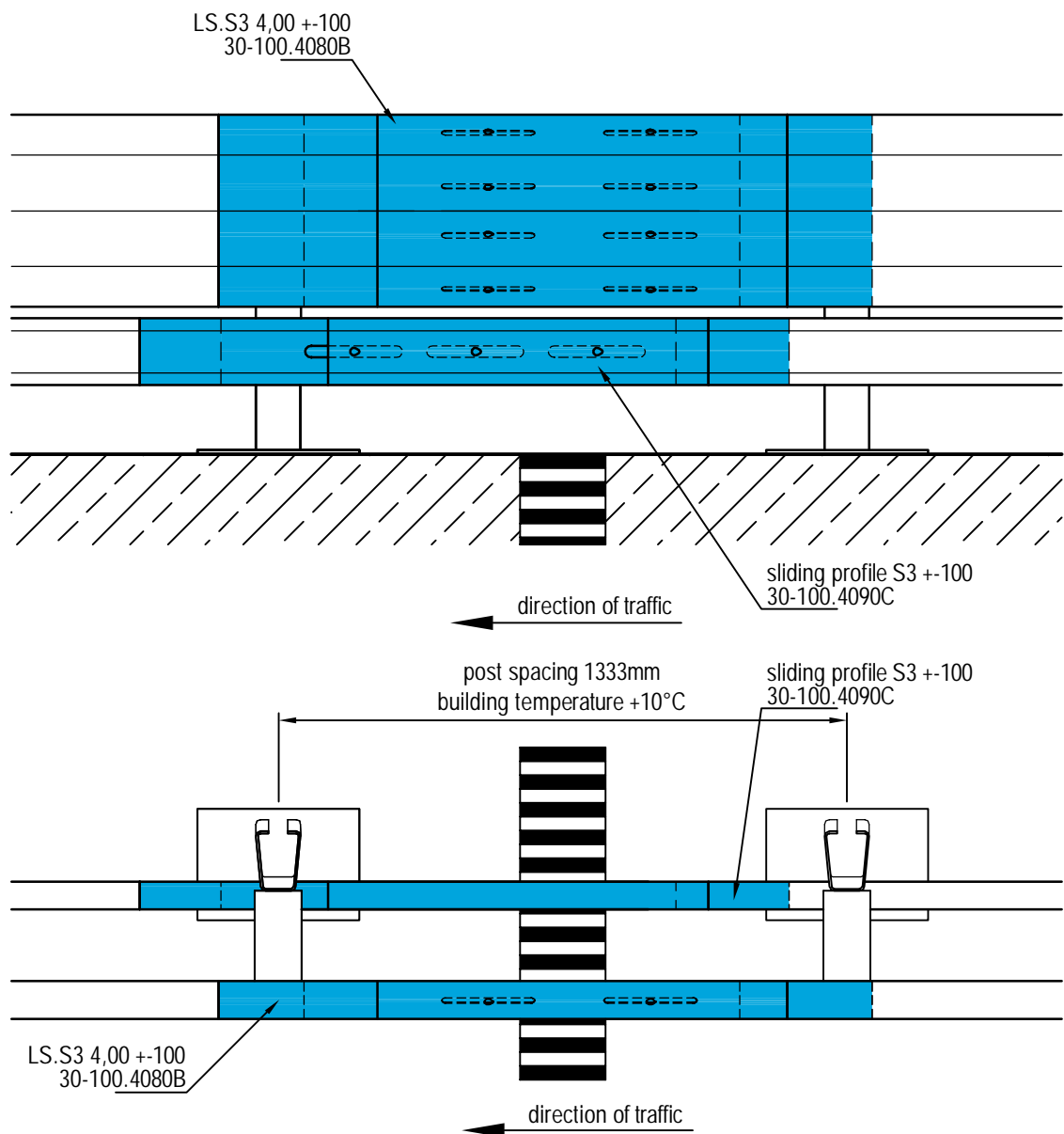

01/2015